



Legislation Details (With Text)

File #: 61180 **Version:** 1 **Name:** Awarding Public Works Contract No. 8898, UW 26 Booster Pump Upgrade.

Type: Resolution **Status:** Passed

File created: 7/1/2020 **In control:** Engineering Division

On agenda: 7/21/2020 **Final action:** 7/21/2020

Enactment date: 7/27/2020 **Enactment #:** RES-20-00510

Title: Awarding Public Works Contract No. 8898, UW 26 Booster Pump Upgrade. (9th AD)

Sponsors: BOARD OF PUBLIC WORKS

Indexes:

Code sections:

Attachments: 1. 8898.pdf, 2. 8898 Contract.pdf

Date	Ver.	Action By	Action	Result
7/21/2020	1	COMMON COUNCIL		
7/8/2020	1	BOARD OF PUBLIC WORKS	RECOMMEND TO COUNCIL TO ADOPT UNDER SUSPENSION OF RULES 2.04, 2.05, 2.24, & 2.25 - REPORT OF OFFICER	Pass
7/1/2020	1	Engineering Division	Refer	

The proposed resolution authorizes awarding the contract for the UW 26 Booster Pump upgrade at a total cost of \$76,950 including contingency. Sufficient budget authority for the proposed contract is included in the Munis project for Water Utility Vehicle Improvement (12661-86-150).

Awarding Public Works Contract No. 8898, UW 26 Booster Pump Upgrade. (9th AD)

BE IT RESOLVED, that the following low bids for miscellaneous improvements be accepted and that the Mayor and City Clerk be and are hereby authorized and directed to enter into a contract with the low bidder contained herein, subject to the Contractor's compliance with Section 39.02 of the Madison General Ordinances concerning compliance with the Affirmative Action provisions **and subject to the Contractor's compliance with Section 33.07 of the Madison General Ordinances regarding Best Value Contracting:**

BE IT FURTHER RESOLVED, that the funds be encumbered to cover the cost of the projects contained herein.

See attached document (Contract No. 8898) for itemization of bids.

Digitally signed by enssd
DN: cn=enssd,
email=sdannerrivers@city
ofmadison.com
Date: 2020.07.29 11:46:56
-05'00'

PROJECT

CONTRACTOR

AMOUNT OF BID

CONTRACT NO. 8898
UW 26 BOOSTER PUMP UPGRADE

MONONA PLUMBING AND FIRE PROTECTION, INC.

\$71,253.00

Acct. No. 12661-86-150: 53410 (72090)
Contingency 8%+

\$71,253.00
5,697.00

GRAND TOTAL

\$76,950.00

Jurisdiction: Wisconsin

Demographics

Company Name: Fidelity and Deposit Company of Maryland
 SBS Company Number: 54219634
 Domicile Type: Foreign
 NAIC Group Number: 212 - ZURICH INS GRP
 Merger Flag: No
 NAIC CoCode: 39306
 State of Domicile: Illinois
 Organization Type: Stock
 Short Name:
 FEIN: 13-3046577
 Country of Domicile: United States
 Date of Incorporation: 03/18/1969

Address

Business Address: 1299 ZURICH WAY, SCHAUMBURG, IL 60196-1056, United States
 Mailing Address: 1299 ZURICH WAY, SCHAUMBURG, IL 60196-1056, United States
 Statutory Home Office Address: 1299 ZURICH WAY, SCHAUMBURG, IL 60196-1056, United States
 Main Administrative Office Address: 1299 ZURICH WAY, SCHAUMBURG, IL 60196-1056, United States

Phone, Email, Website

Phone: No results found.
 Email: No results found.
 Website: No results found.

Type	Number
Toll Free Phone	(800) 382-2150
Business Primary Phone	(847) 605-6000
Business Primary Phone	(847) 413-5048

Company Type

Company Type: Property and Casualty
 Status: Active
 Effective Date: 12/31/2018
 Issue Date: 01/01/1982
 Articles of Incorporation Received: No
 Status Reason:
 Legacy State ID: 111700
 Approval Date:
 Article No:
 Status Date: 01/01/1982
 Expiration Date:
 File Date:
 COA Number:

Appointments

Show 10 entries Showing 1 to 2 of 1429 entries

Search: mcke

Licensee Name	License Number	NPN	License Type	Line of Authority	Appointment Date	Effective Date	Expiration Date
PATRICK MCKENNA	650765	650765	Intermediary (Agent) Individual	Casualty	07/23/1996	01/08/2020	03/15/2021
PATRICK MCKENNA	650765	650765	Intermediary (Agent) Individual	Property	07/23/1996	01/08/2020	03/15/2021

Navigation: First Previous 1 Next Last

Line Of Business

Line of Business	Citation Type	Effective Date
Aircraft	Aircraft	01/01/1982
Automobile	Automobile	01/01/1982
Credit Insurance	Credit Insurance	01/01/1982
Fidelity Insurance	Fidelity Insurance	01/01/1982
Fire, Inland Marine and Other Property Insurance	Fire, Inland Marine and Other Property Insurance	01/01/1982
Liability and Incidental Medical Expense Insurance (other than automobile)	Liability and Incidental Medical Expense Insurance (other than automobile)	01/01/1982
Miscellaneous	Miscellaneous	01/01/1982
Ocean Marine Insurance	Ocean Marine Insurance	01/01/1982
Surety Insurance	Surety Insurance	01/01/1982
Workers Compensation Insurance	Workers Compensation Insurance	01/01/1982

Contact

Contact Type	Preferred Name	Name	E-mail	Phone	Address
Registered Agent for Service of Process					Other CORPORATION SERVICE COMPANY 8040 EXCELSIOR DR STE 400 MADISON, WI United States County 53717

Company Merger

No results found.

Name Change History

Previous Name	New Name	Effective Date
	Fidelity and Deposit Company of Maryland	

\$71,253.00
ORIGINAL

BID OF MONONA PLUMBING AND FIRE PROTECTION, INC.

2020

PROPOSAL, CONTRACT, BOND AND SPECIFICATIONS

FOR

UW 26 BOOSTER PUMP UPGRADE

CONTRACT NO. 8898

PROJECT NO.

MUNIS NO. 12661-86-260

IN

MADISON, DANE COUNTY, WISCONSIN

AWARDED BY THE COMMON COUNCIL
MADISON, WISCONSIN ON JULY 21, 2020

CITY ENGINEERING DIVISION
1600 EMIL STREET
MADISON, WISCONSIN 53713

<https://bidexpress.com/login>

**UW 26 BOOSTER PUMP UPGRADE
CONTRACT NO. 8898**

INDEX

SECTION A: ADVERTISEMENT FOR BIDS AND INSTRUCTIONS TO BIDDERSA-1
SECTION B: PROPOSAL SECTIONB-1
SECTION C: SMALL BUSINESS ENTERPRISE (NOT APPLICABLE) C-1
SECTION D: SPECIAL PROVISIONS D-1
SECTION E: BIDDER'S ACKNOWLEDGEMENTE-1
SECTION F: BEST VALUE CONTRACTING F-1
SECTION G: BID BOND G-1
SECTION H: AGREEMENT H-1
SECTION I: PAYMENT AND PERFORMANCE BOND I-1

This Proposal, and Agreement
prepared by:

**MADISON WATER UTILITY
CITY OF MADISON
MADISON, DANE COUNTY, WISCONSIN**

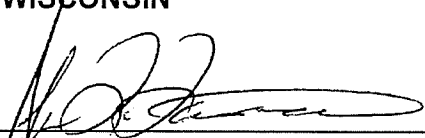

Alan L. Larson, PE, BCEE – Chief Engineer
May 28, 2020

RFP:

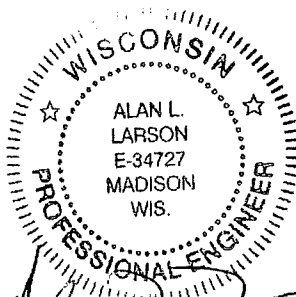
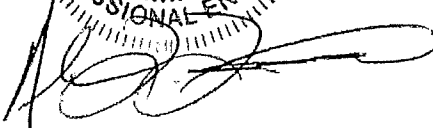

May 28, 2020

SECTION A: ADVERTISEMENT FOR BIDS AND INSTRUCTIONS TO BIDDERS

REQUEST FOR BID FOR PUBLIC WORKS CONSTRUCTION CITY OF MADISON, WISCONSIN

A BEST VALUE CONTRACTING MUNICIPALITY

PROJECT NAME:	UW 26 BOOSTER PUMP UPGRADE
CONTRACT NO.:	8898
BID BOND	5%
PREQUALIFICATION APPLICATION DUE (2:00 P.M.)	6/18/2020
BID SUBMISSION (2:00 P.M.)	6/25/2020
BID OPEN (2:30 P.M.)	6/25/2020
PUBLISHED IN WSJ	6/11/2020 & 6/18/2020

PREQUALIFICATION APPLICATION: Forms are available at the same location or on our website, www.cityofmadison.com/business/pw/forms.cfm. If not currently prequalified in the categories listed in Section A, an amendment to your Prequalification will need to be submitted prior to the same due date. Postmark is not applicable.

BIDS TO BE SUBMITTED: Bids may be submitted on line at www.bidexpress.com, or by hand at 1600 Emil St. Please note that in support of social distancing during COVID-19, the doors at 1600 Emil St. are locked, but there is a sign with phone numbers on the door. Please call one of the numbers on the door and staff will come to the door to receive your bid. Until further notice, the bid openings will be closed to the public to support the guidance of social distancing, as the City responds responsibly to COVID-19 impacts to services. The bids will be posted online after the bid opening. If you have any questions, please call Alane Boutelle at (608) 267-1197, or John Fahrney, (608) 266-9091.

STANDARD SPECIFICATIONS

The City of Madison's Standard Specifications for Public Works Construction - 2020 Edition, as supplemented and amended from time to time, forms a part of these contract documents as if attached hereto.

These standard specifications are available on the City of Madison Public Works website, www.cityofmadison.com/Business/PW/specs.cfm.

The Contractor shall review these Specifications prior to preparation of proposals for the work to be done under this contract, with specific attention to Article 102, "BIDDING REQUIREMENTS AND CONDITIONS" and Article 103, "AWARD AND EXECUTION OF THE CONTRACT." For the convenience of the bidder, below are highlights of three subsections of the specifications.

SECTION 102.1: PRE-QUALIFICATION OF BIDDERS

In accordance with Wisconsin State Statutes 66.0901 (2) and (3), all bidders must submit to the Board of Public Works proof of responsibility on forms furnished by the City. The City requires that all bidders be qualified on a biennial basis.

Bidders must present satisfactory evidence that they have been regularly engaged in the type of work specified herein and they are fully prepared with necessary capital, materials, machinery and supervisory personnel to conduct the work to be contracted for to the satisfaction of the City. All bidders must be pre-qualified by the Board of Public Works for the type of construction on which they are bidding prior to the opening of the bid.

In accordance with Section 39.02(9)(a)l. of the General Ordinances, all bidders shall submit in writing to the Affirmative Action Division Manager of the City of Madison, a Certificate of Compliance or an Affirmative Action Plan at the same time or prior to the submission of the proof of responsibility forms.

The bidder shall be disqualified if the bidder fails to or refuses to, prior to opening of the bid, submit a Certificate of compliance, Affirmative Action Plan or Affirmative Action Data Update, as applicable, as defined by Section 39.02 of the General Ordinances (entitled Affirmative Action) and as required by Section 102.11 of the Standard Specifications.

SECTION 102.4 PROPOSAL

No bid will be accepted that does not contain an adequate or reasonable price for each and every item named in the Schedule of Unit Prices.

A lump sum bid for the work in accordance with the plans and specifications is required. The lump sum bid must be the same as the total amounts bid for the various items and it shall be inserted in the space provided.

All papers bound with or attached to the proposal form are considered a part thereof and must not be detached or altered when the proposal is submitted. The plans, specifications and other documents designated in the proposal form will be considered a part of the proposal whether attached or not.

A proposal submitted by an individual shall be signed by the bidder or by a duly authorized agent. A proposal submitted by a partnership shall be signed by a member/partner or by a duly authorized agent thereof. A proposal submitted by a corporation shall be signed by an authorized officer or duly authorized registered agent of such corporation, and the proposal shall show the name of the State under the laws of which such corporation was chartered. The required signatures shall in all cases appear in the space provided thereof on the proposal.

Each proposal shall be placed, together with the proposal guaranty, in a sealed envelope, so marked as to indicate name of project, the contract number or option to which it applies, and the name and address of the Contractor or submitted electronically through Bid Express (www.bidexpress.com). Proposals will be accepted at the location, the time and the date designated in the advertisement. Proposals received after the time and date designated will be returned to the bidder unopened.

SECTION 102.5: BID DEPOSIT (PROPOSAL GUARANTY)

All bids, sealed or electronic, must be accompanied with a Bid Bond (City of Madison form) equal to at least 5% of the bid or a Certificate of Annual/Biennial Bid Bond or certified check, payable to the City Treasurer. Bid deposit of the successful bidders shall be returned within forty-eight (48) hours following execution of the contract and bond as required.

MINOR DISCREPENCIES

Bidder is responsible for submitting all forms necessary for the City to determine compliance with State and City bidding requirements. Notwithstanding any language to the contrary contained herein, the City may exercise its discretion to allow bidders to correct or supplement submissions after bid opening, if the minor discrepancy, bid irregularity or omission is insignificant and not one related to price, quality, quantity, time of completion or performance of the contract.

Bidders for this Contract(s) must be Pre-Qualified for at least one of the following type(s) of construction denoted by an

Building Demolition

- 101 Asbestos Removal
120 House Mover

- 110 Building Demolition

Street, Utility and Site Construction

- 201 Asphalt Paving
205 Blasting
210 Boring/Pipe Jacking
215 Concrete Paving
220 Con. Sidewalk/Curb & Gutter/Misc. Flat Work
221 Concrete Bases and Other Concrete Work
222 Concrete Removal
225 Dredging
230 Fencing
235 Fiber Optic Cable/Conduit Installation
240 Grading and Earthwork
241 Horizontal Saw Cutting of Sidewalk
242 Infrared Seamless Patching
245 Landscaping, Maintenance
246 Ecological Restoration
250 Landscaping, Site and Street
251 Parking Ramp Maintenance
252 Pavement Marking
255 Pavement Sealcoating and Crack Sealing
260 Petroleum Above/Below Ground Storage Tank Removal/Installation
262 Playground Installer

- 265 Retaining Walls, Precast Modular Units
270 Retaining Walls, Reinforced Concrete
275 Sanitary, Storm Sewer and Water Main Construction
276 Sawcutting
280 Sewer Lateral Drain Cleaning/Internal TV Insp.
285 Sewer Lining
290 Sewer Pipe Bursting
295 Soil Borings
300 Soil Nailing
305 Storm & Sanitary Sewer Laterals & Water Svc.
310 Street Construction
315 Street Lighting
318 Tennis Court Resurfacing
320 Traffic Signals
325 Traffic Signing & Marking
332 Tree pruning/removal
333 Tree, pesticide treatment of
335 Trucking
340 Utility Transmission Lines including Natural Gas, Electrical & Communications
399 Other_____

Bridge Construction

- 501 Bridge Construction and/or Repair

Building Construction

- 401 Floor Covering (including carpet, ceramic tile installation, rubber, VCT)
402 Building Automation Systems
403 Concrete
404 Doors and Windows
405 Electrical - Power, Lighting & Communications
410 Elevator - Lifts
412 Fire Suppression
413 Furnishings - Furniture and Window Treatments
415 General Building Construction, Equal or Less than \$250,000
420 General Building Construction, \$250,000 to \$1,500,000
425 General Building Construction, Over \$1,500,000
428 Glass and/or Glazing
429 Hazardous Material Removal
430 Heating, Ventilating and Air Conditioning (HVAC)
433 Insulation - Thermal
435 Masonry/Tuck pointing

- 437 Metals
440 Painting and Wallcovering
445 Plumbing
450 Pump Repair
455 Pump Systems
460 Roofing and Moisture Protection
464 Tower Crane Operator
461 Solar Photovoltaic/Hot Water Systems
465 Soil/Groundwater Remediation
466 Warning Sirens
470 Water Supply Elevated Tanks
475 Water Supply Wells
480 Wood, Plastics & Composites - Structural & Architectural
499 Other_____

State of Wisconsin Certifications

- 1 Class 5 Blaster - Blasting Operations and Activities 2500 feet and closer to inhabited buildings for quarries, open pits and road cuts.
2 Class 6 Blaster - Blasting Operations and Activities 2500 feet and closer to inhabited buildings for trenches, site excavations, basements, underwater demolition, underground excavations, or structures 15 feet or less in height.
3 Class 7 Blaster - Blasting Operations and Activities for structures greater than 15' in height, bridges, towers, and any of the objects or purposes listed as "Class 5 Blaster or Class 6 Blaster".
4 Petroleum Above/Below Ground Storage Tank Removal and Installation (Attach copies of State Certifications.)
5 Hazardous Material Removal (Contractor to be certified for asbestos and lead abatement per the Wisconsin Department of Health Services, Asbestos and Lead Section (A&LS).) See the following link for application: www.dhs.wisconsin.gov/Asbestos/Cert. State of Wisconsin Performance of Asbestos Abatement Certificate must be attached.
6 Certification number as a Certified Arborist or Certified Tree Worker as administered by the International Society of Arboriculture
7 Pesticide application (Certification for Commercial Applicator For Hire with the certification in the category of turf and landscape (3.0) and possess a current license issued by the DATCP)
8 State of Wisconsin Master Plumbers License.

SECTION B: PROPOSAL

Please refer to the
Bid Express Website
at <https://bidexpress.com>
look up contract number
and go to
Section B: Proposal Page

You can access all City of Madison bid solicitations for FREE at www.bidexpress.com

Click on the "Register for Free" button and follow the instructions to register your company and yourself. You will be asked for a payment subscription preference, since you may wish to bid online someday. Simply choose the method to pay on a 'per bid' basis. This requires no payment until / unless you actually bid online. You can also choose the monthly subscription plan at this time. You will, however, be asked to provide payment information. Remember, you can change your preference at anytime. You will then be able to complete your free registration and have full access to the site. Your free access does not require completion of the 'Digital ID' process, so you will have instant access for viewing and downloading. To be prepared in case you ever do wish to bid online, you may wish to establish your digital ID also, since you cannot bid without a Digital ID.

If you have any problems with the free registration process, you can call the bidexpress help team, toll free at 1-888-352-2439 (option 1, option1).

SECTION C: SMALL BUSINESS ENTERPRISE

**Instructions to Bidders
City of Madison
SBE Program Information**

SBE NOT APPLICABLE

SECTION D: SPECIAL PROVISIONS

UW 26 BOOSTER PUMP UPGRADE CONTRACT NO. 8898

It is the intent of these Special Provisions to set forth the final contractual intent as to the matter involved and shall prevail over the Standard Specifications and plans whenever in conflict therewith. In order that comparisons between the Special Provisions can be readily made, the numbering system for the Special Provisions is equivalent to that of the Specifications.

Whenever in these Specifications the term "Standard Specifications" appears, it shall be taken to refer to the City of Madison Standard Specifications for Public Works Construction and Supplements thereto.

SECTION 102.11: BEST VALUE CONTRACTING

This Contract shall be considered a Best Value Contract if the Contractor's bid is equal to or greater than \$63,500 for a single trade contract; or equal to or greater than \$311,500 for a multi-trade contract pursuant to MGO 33.07(7).

SECTION 109.2: PROSECUTION OF THE WORK

All work described in this Contract shall be completed and accepted by the Owner no later than 60 calendar days from written Notice to Proceed.

NON STANDARD BID ITEMS

BID ITEM 90000 – BASE BID.

DESCRIPTION: The BASE BID shall be measured as a Lump Sum of the required construction and installation of all building components and the completion, and turn-in of all deliverables as outlined in the plans and specifications.

METHOD OF MEASUREMENT: The BASE BID shall be measured as a Lump Sum of the required construction and installations described in the plans and specifications. Partial Payments shall be requested no more often than monthly as a percentage of the actual work completed. Request for payment for materials purchased but not installed that are included in the partial payment request shall be accompanied with paid invoices and delivery receipts for the project materials delivered to the project site.

Typical Specifications – SETTING PLAN 6" 2823A & C BENT FORM BASE

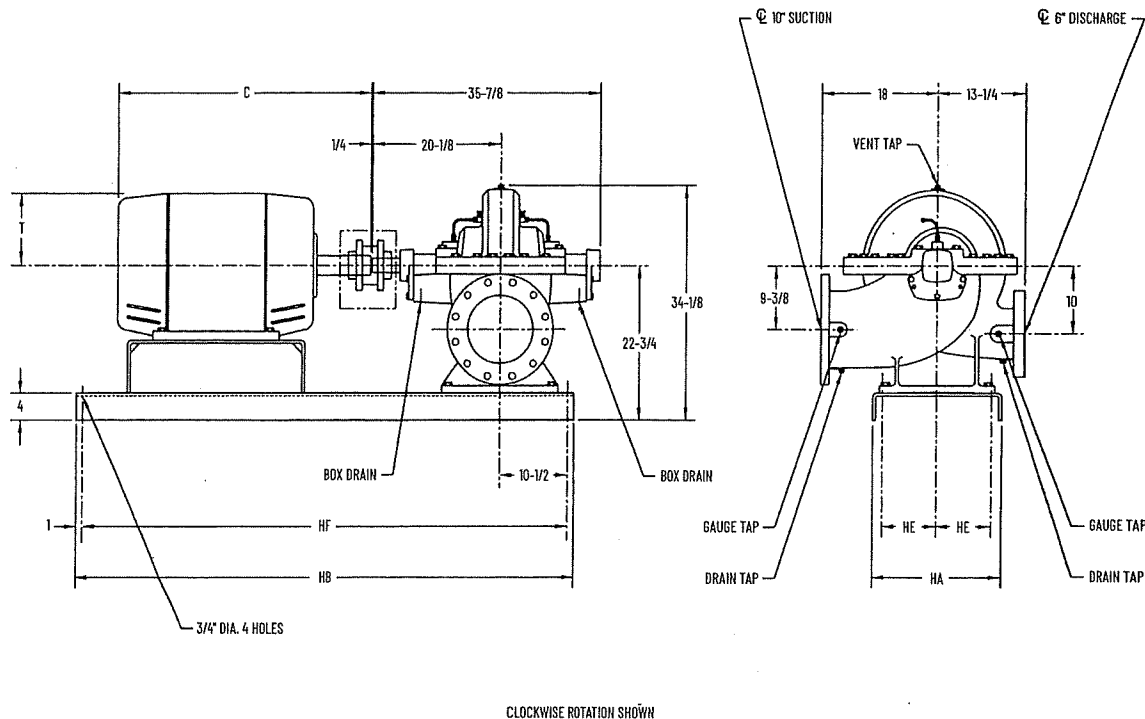

CLOCKWISE ROTATION SHOWN

UNIT DIMENSIONS						
MOTOR FRAME SIZE	BASE				MOTOR	
	HA	HB	HE	HF	C	T
256T	20	54	8-1/2	52	22-3/8	6-3/8
284TS	20	60	8-1/2	58	22-1/8	7
284T	20	60	8-1/2	58	23-1/2	7
286TS	20	60	8-1/2	58	23-5/8	7
286T	20	60	8-1/2	58	25	7
324TS	20	60	8-1/2	58	24-5/8	8
324T	20	60	8-1/2	58	26-1/8	8
326TS	20	60	8-1/2	58	26-1/8	8
326T	20	60	8-1/2	58	27-5/8	8
364TS	20	60	8-1/2	58	26-5/8	9-1/4
364T	20	60	8-1/2	58	28-3/4	9-1/4

UNIT DIMENSIONS						
MOTOR FRAME SIZE	BASE				MOTOR	
	HA	HB	HE	HF	C	T
365TS	20	60	8-1/2	58	27-5/8	9-1/4
365T	20	60	8-1/2	58	29-3/4	9-1/4
404TS	24	66	10-1/2	64	29-5/8	10-1/4
404T	24	66	10-1/2	64	32-5/8	10-1/4
405TS	24	66	10-1/2	64	31-1/8	10-1/4
405T	24	66	10-1/2	64	34-1/8	10-1/4
444TS	24	78	10-1/2	76	37-1/8	11-1/4
444T	24	78	10-1/2	76	37-7/8	11-1/4
445TS	24	78	10-1/2	76	36-1/8	11-1/4
445T	24	78	10-1/2	76	39-7/8	11-1/4

NOTES:

All flanges are standard 125# ANSI drilling. Optional 250# ANSI flanges are available.

All dimensions are in inches unless noted.

Rotation is always viewed from the driver end. For C.C.W. rotation, suction and discharge positions will be on opposite sides of that shown above and dimensions in the end view will be reversed.

Bases are designed to be completely filled with grout.

Not for construction, installation, or application purposes unless certified. Dimensions shown may vary due to normal manufacturing tolerances.

SECTION E: BIDDERS ACKNOWLEDGEMENT

CONTRACT TITLE: UW 26 BOOSTER UPGRADE

CONTRACT NO. 8898

Bidder must state a Unit Price and Total Bid for each item. The Total Bid for each item must be the product of quantity, by Unit Price. The Grand Total must be the sum of the Total Bids for the various items. In case of multiplication errors or addition errors, the Grand Total with corrected multiplication and/or addition shall determine the Grand Total bid for each contract. The Unit Price and Total Bid must be entered numerically in the spaces provided. All words and numbers shall be written in ink.

1. The undersigned having familiarized himself/herself with the Contract documents, including Advertisement for Bids, Instructions to Bidders, Form of Proposal, City of Madison Standard Specifications for Public Works Construction - 2020 Edition thereto, Form of Agreement, Form of Bond, and Addenda issued and attached to the plans and specifications on file in the office of the City Engineer, hereby proposes to provide and furnish all the labor, materials, tools, and expendable equipment necessary to perform and complete in a workmanlike manner the specified construction on this project for the City of Madison; all in accordance with the plans and specifications as prepared by the City Engineer, including Addenda to the Contract Nos. _____ through _____ issued thereto, at the prices for said work as contained in this proposal. (Electronic bids submittals shall acknowledge addendum under Section E and shall not acknowledge here)
2. If awarded the Contract, we will initiate action within seven (7) days after notification or in accordance with the date specified in the contract to begin work and will proceed with diligence to bring the project to full completion within the number of work days allowed in the Contract or by the calendar date stated in the Contract.
3. The undersigned Bidder or Contractor certifies that he/she is not a party to any contract, combination in form of trust or otherwise, or conspiracy in restraint of trade or commerce or any other violation of the anti-trust laws of the State of Wisconsin or of the United States, with respect to this bid or contract or otherwise.
4. I hereby certify that I have met the Bid Bond Requirements as specified in Section 102.5. (IF BID BOND IS USED, IT SHALL BE SUBMITTED ON THE FORMS PROVIDED BY THE CITY. FAILURE TO DO SO MAY RESULT IN REJECTION OF THE BID).
5. I hereby certify that all statements herein are made on behalf of MONGNA PLUMBING & FIRE (name of corporation, partnership, or person submitting bid) a corporation organized and existing under the laws of the State of WISCONSIN a partnership consisting of _____; an individual trading as _____; of the City of _____ State of _____; that I have examined and carefully prepared this Proposal, from the plans and specifications and have checked the same in detail before submitting this Proposal; that I have fully authority to make such statements and submit this Proposal in (its, their) behalf; and that the said statements are true and correct.

[Signature]
SIGNATURE

Project Manager
TITLE, IF ANY

Sworn and subscribed to before me this 24th day of June, 2022

[Signature]
(Notary Public or other officer authorized to administer oaths)

My Commission Expires 12/26/2022

Bidders shall not add any conditions or qualifying statements to this Proposal.

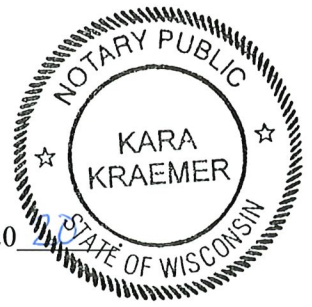

SECTION F: BEST VALUE CONTRACTING

UW 26 BOOSTER PUMP UPGRADE CONTRACT NO. 8898

Best Value Contracting

1. The Contractor shall indicate the non-apprenticeable trades used on this contract.

2. Madison General Ordinance (M.G.O.), 33.07(7), does provide for some exemptions from the active apprentice requirement. Apprenticeable trades are those trades considered apprenticeable by the State of Wisconsin. Please check applicable box if you are seeking an exemption.
 - Contractor has a total skilled workforce of four or less individuals in all apprenticeable trades combined.
 - No available trade training program; The Contractor has been rejected by the only available trade training program, or there is no trade training program within 90 miles.
 - Contractor is not using an apprentice due to having a journey worker on layoff status, provided the journey worker was employed by the contractor in the past six months.
 - First-time Contractor on City of Madison Public Works contract requests a onetime exemption but intends to comply on all future contracts and is taking steps typical of a "good faith" effort.
 - Contractor has been in business less than one year.
 - Contractor doesn't have enough journeyman trade workers to qualify for a trade training program in that respective trade.
 - An exemption is granted in accordance with a time period of a "Documented Depression" as defined by the State of Wisconsin.

3. The Contractor shall indicate on the following section which apprenticeable trades are to be used on this contract. Compliance with active apprenticeship, to the extent required by M.G.O. 33.07(7), shall be satisfied by documentation from an applicable trade training body; an apprenticeship contract with the Wisconsin Department of Workforce Development or a similar agency in another state; or the U.S Department of Labor. This documentation is required prior to the Contractor beginning work on the project site.
 - The Contractor has reviewed the list and shall not use any apprenticeable trades on this project.

**UW 26 BOOSTER PUMP UPGRADE
CONTRACT NO. 8898**

LIST APPRENTICABLE TRADES (check all that apply to your work to be performed on this contract)

- BRICKLAYER
- CARPENTER
- CEMENT MASON / CONCRETE FINISHER
- CEMENT MASON (HEAVY HIGHWAY)
- CONSTRUCTION CRAFT LABORER
- DATA COMMUNICATION INSTALLER
- ELECTRICIAN
- ENVIRONMENTAL SYSTEMS TECHNICIAN / HVAC SERVICE TECH/HVAC INSTALL / SERVICE
- GLAZIER
- HEAVY EQUIPMENT OPERATOR / OPERATING ENGINEER
- INSULATION WORKER (HEAT & FROST)
- IRON WORKER
- IRON WORKER (ASSEMBLER, METAL BLDGS)
- PAINTER & DECORATOR
- PLASTERER
- PLUMBER
- RESIDENTIAL ELECTRICIAN
- ROOFER & WATER PROOFER
- SHEET METAL WORKER
- SPRINKLER FITTER
- STEAMFITTER
- STEAMFITTER (REFRIGERATION)
- STEAMFITTER (SERVICE)
- TAPER & FINISHER
- TELECOMMUNICATIONS (VOICE, DATA & VIDEO) INSTALLER-TECHNICIAN
- TILE SETTER

Contract: 8898 UW 26 Booster Pump Upgrade

Project No. 12661

Bid Date: June 25, 2020

Company Name Printed: Monona Plumbing and Fire Protection

Bidders Signature



Bidders Name Printed: Dan Siehr

Title: Section B: Proposal Page

Item Code: 90000

Demolition and removal of existing pump #1 and installation of a 100 hp Fairbanks split case Centrifugal Booster Pump supplied by MWU as specified and illustrated in the attached drawings and pump manufacturer setting plan.

1

Lump Sum

\$71,253.00

SECTION G: BID BOND

LET ALL KNOW BY THESE DOCUMENTS PRESENTED, THAT Principal and Surety, as identified below, are held and firmly bound unto the City of Madison, (hereinafter referred to as the "Obligee"), in the sum of five per cent (5%) of the amount of the total bid or bids of the Principal herein accepted by the Obligee, for the payment of which the Principal and the Surety bind themselves, their heirs, executors, administrators, successors and assigns, jointly and severally, firmly by these presents.

The conditions of this obligation are such that, whereas the Principal has submitted, to the City of Madison a certain bid, including the related alternate, and substitute bids attached hereto and hereby made a part hereof, to enter into a contract in writing for the construction of:

UW 26 BOOSTER PUMP UPGRADE CONTRACT NO. 8898

1. If said bid is rejected by the Obligee, then this obligation shall be void.
2. If said bid is accepted by the Obligee and the Principal shall execute and deliver a contract in the form specified by the Obligee (properly completed in accordance with said bid) and shall furnish a bond for his/her faithful performance of said contract, and for the payment of all persons performing labor or furnishing materials in connection therewith, and shall in all other respects perform the agreement created by the acceptance of said bid, then this obligation shall be void.

If said bid is accepted by the Obligee and the Principal shall fail to execute and deliver the contract and the performance and payment bond noted in 2. above executed by this Surety, or other Surety approved by the City of Madison, all within the time specified or any extension thereof, the Principal and Surety agree jointly and severally to forfeit to the Obligee as liquidated damages the sum mentioned above, it being understood that the liability of the Surety for any and all claims hereunder shall in no event exceed the sum of this obligation as stated, and it is further understood that the Principal and Surety reserve the right to recover from the Obligee that portion of the forfeited sum which exceed the actual liquidated damages incurred by the Obligee.

The Surety, for value received, hereby stipulates and agrees that the obligations of said Surety and its bond shall be in no way impaired or affected by an extension of the time within which the Obligee may accept such bid, and said Surety does hereby waive notice of any such extension.

IN WITNESS WHEREOF, the Principal and the Surety have hereunto set their hands and seals, and such of them as are corporations have caused their corporate seals to be hereto affixed and these presents to be signed by their proper officers, on the day and year set forth below.

Seal PRINCIPAL

Monona Plumbing and Fire Protection, Inc.

Name of Principal

Lisa Reiter

By

06-25-2020

Date

Lisa Reiter, He manager

Name and Title

Seal SURETY

Fidelity and Deposit Company of Maryland

Name of Surety

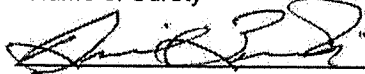

By

06-25-2020

Date

David Zenobi, Attorney-in-Fact

Name and Title

This certifies that I have been duly licensed as an agent for the above company in Wisconsin under National Provider No. 18708052 for the year 2020, and appointed as attorney in fact with authority to execute this bid bond and the payment and performance bond referred to above, which power of attorney has not been revoked.

06-25-2020

Date



Agent Signature

PO Box 259408

Address

Madison, WI 53725-9408

City, State and Zip Code

608-252-9674

Telephone Number

NOTE TO SURETY & PRINCIPAL

The bid submitted which this bond guarantees shall be rejected if the following instrument is not attached to this bond:

Power of Attorney showing that the agent of Surety is currently authorized to execute bonds on behalf of the Surety, and in the amounts referenced above.

**ZURICH AMERICAN INSURANCE COMPANY
COLONIAL AMERICAN CASUALTY AND SURETY COMPANY
FIDELITY AND DEPOSIT COMPANY OF MARYLAND
POWER OF ATTORNEY**

KNOW ALL MEN BY THESE PRESENTS: That the ZURICH AMERICAN INSURANCE COMPANY, a corporation of the State of New York, the COLONIAL AMERICAN CASUALTY AND SURETY COMPANY, a corporation of the State of Illinois, and the FIDELITY AND DEPOSIT COMPANY OF MARYLAND a corporation of the State of Illinois (herein collectively called the "Companies"), by **Robert D. Murray, Vice President**, in pursuance of authority granted by Article V, Section 8, of the By-Laws of said Companies, which are set forth on the reverse side hereof and are hereby certified to be in full force and effect on the date hereof, do hereby nominate, constitute, and appoint, **Judith A. WALKER, Elizabeth MOSCA, David ZENOBI, Patrick A. MCKENNA and Brooke L. PARKER, all of Madison, Wisconsin**, Each, its true and lawful agent and Attorney-in-Fact, to make, execute, seal and deliver, for, and on its behalf as surety, and as its act and deed: any and all bonds and undertakings, **EXCEPT bonds on behalf of Independent Executors, Community Survivors and Community Guardians**, and the execution of such bonds or undertakings in pursuance of these presents, shall be as binding upon said Companies, as fully and amply, to all intents and purposes, as if they had been duly executed and acknowledged by the regularly elected officers of the ZURICH AMERICAN INSURANCE COMPANY at its office in New York, New York., the regularly elected officers of the COLONIAL AMERICAN CASUALTY AND SURETY COMPANY at its office in Owings Mills, Maryland., and the regularly elected officers of the FIDELITY AND DEPOSIT COMPANY OF MARYLAND at its office in Owings Mills, Maryland., in their own proper persons.

The said Vice President does hereby certify that the extract set forth on the reverse side hereof is a true copy of Article V, Section 8, of the By-Laws of said Companies and is now in force.

IN WITNESS WHEREOF, the said Vice-President has hereunto subscribed his/her names and affixed the Corporate Seals of the said **ZURICH AMERICAN INSURANCE COMPANY, COLONIAL AMERICAN CASUALTY AND SURETY COMPANY, and FIDELITY AND DEPOSIT COMPANY OF MARYLAND**, this 27th day of February, A.D. 2020.



**ATTEST:
ZURICH AMERICAN INSURANCE COMPANY
COLONIAL AMERICAN CASUALTY AND SURETY COMPANY
FIDELITY AND DEPOSIT COMPANY OF MARYLAND**

By: *Robert D. Murray*
Vice President

By: *Dawn E. Brown*
Secretary

**State of Maryland
County of Baltimore**

On this 27th day of February, A.D. 2020, before the subscriber, a Notary Public of the State of Maryland, duly commissioned and qualified, **Robert D. Murray, Vice President and Dawn E. Brown, Secretary** of the Companies, to me personally known to be the individuals and officers described in and who executed the preceding instrument, and acknowledged the execution of same, and being by me duly sworn, depose and saith, that he/she is the said officer of the Company aforesaid, and that the seals affixed to the preceding instrument are the Corporate Seals of said Companies, and that the said Corporate Seals and the signature as such officer were duly affixed and subscribed to the said instrument by the authority and direction of the said Corporations.

IN TESTIMONY WHEREOF, I have hereunto set my hand and affixed my Official Seal the day and year first above written.



Constance A. Dunn, Notary Public
My Commission Expires: July 9, 2023

EXTRACT FROM BY-LAWS OF THE COMPANIES

"Article V, Section 8, Attorneys-in-Fact. The Chief Executive Officer, the President, or any Executive Vice President or Vice President may, by written instrument under the attested corporate seal, appoint attorneys-in-fact with authority to execute bonds, policies, recognizances, stipulations, undertakings, or other like instruments on behalf of the Company, and may authorize any officer or any such attorney-in-fact to affix the corporate seal thereto; and may with or without cause modify or revoke any such appointment or authority at any time."

CERTIFICATE

I, the undersigned, Vice President of the ZURICH AMERICAN INSURANCE COMPANY, the COLONIAL AMERICAN CASUALTY AND SURETY COMPANY, and the FIDELITY AND DEPOSIT COMPANY OF MARYLAND, do hereby certify that the foregoing Power of Attorney is still in full force and effect on the date of this certificate; and I do further certify that Article V, Section 8, of the By- Laws of the Companies is still in force.

This Power of Attorney and Certificate may be signed by facsimile under and by authority of the following resolution of the Board of Directors of the ZURICH AMERICAN INSURANCE COMPANY at a meeting duly called and held on the 15th day of December 1998.

RESOLVED: "That the signature of the President or a Vice President and the attesting signature of a Secretary or an Assistant Secretary and the Seal of the Company may be affixed by facsimile on any Power of Attorney...Any such Power or any certificate thereof bearing such facsimile signature and seal shall be valid and binding on the Company."

This Power of Attorney and Certificate may be signed by facsimile under and by authority of the following resolution of the Board of Directors of the COLONIAL AMERICAN CASUALTY AND SURETY COMPANY at a meeting duly called and held on the 5th day of May, 1994, and the following resolution of the Board of Directors of the FIDELITY AND DEPOSIT COMPANY OF MARYLAND at a meeting duly called and held on the 10th day of May, 1990.

RESOLVED: "That the facsimile or mechanically reproduced seal of the company and facsimile or mechanically reproduced signature of any Vice-President, Secretary, or Assistant Secretary of the Company, whether made heretofore or hereafter, wherever appearing upon a certified copy of any power of attorney issued by the Company, shall be valid and binding upon the Company with the same force and effect as though manually affixed.

IN TESTIMONY WHEREOF, I have hereunto subscribed my name and affixed the corporate seals of the said Companies, this 25 day of June, 2020.



By: Brian M. Hodges
Vice President

TO REPORT A CLAIM WITH REGARD TO A SURETY BOND, PLEASE SUBMIT A COMPLETE DESCRIPTION OF THE CLAIM INCLUDING THE PRINCIPAL ON THE BOND, THE BOND NUMBER, AND YOUR CONTACT INFORMATION TO:

Zurich Surety Claims
1299 Zurich Way
Schaumburg, IL 60196-1056
www.reportsfclaims@zurichna.com
800-626-4577

ORIGINAL
BOND

SECTION G: BID BOND

LET ALL KNOW BY THESE DOCUMENTS PRESENTED, THAT Principal and Surety, as identified below, are held and firmly bound unto the City of Madison, (hereinafter referred to as the "Obligee"), in the sum of five per cent (5%) of the amount of the total bid or bids of the Principal herein accepted by the Obligee, for the payment of which the Principal and the Surety bind themselves, their heirs, executors, administrators, successors and assigns, jointly and severally, firmly by these presents.

The conditions of this obligation are such that, whereas the Principal has submitted, to the City of Madison a certain bid, including the related alternate, and substitute bids attached hereto and hereby made a part hereof, to enter into a contract in writing for the construction of:

UW 26 BOOSTER PUMP UPGRADE CONTRACT NO. 8898

1. If said bid is rejected by the Obligee, then this obligation shall be void.
2. If said bid is accepted by the Obligee and the Principal shall execute and deliver a contract in the form specified by the Obligee (properly completed in accordance with said bid) and shall furnish a bond for his/her faithful performance of said contract, and for the payment of all persons performing labor or furnishing materials in connection therewith, and shall in all other respects perform the agreement created by the acceptance of said bid, then this obligation shall be void.

If said bid is accepted by the Obligee and the Principal shall fail to execute and deliver the contract and the performance and payment bond noted in 2. above executed by this Surety, or other Surety approved by the City of Madison, all within the time specified or any extension thereof, the Principal and Surety agree jointly and severally to forfeit to the Obligee as liquidated damages the sum mentioned above, it being understood that the liability of the Surety for any and all claims hereunder shall in no event exceed the sum of this obligation as stated, and it is further understood that the Principal and Surety reserve the right to recover from the Obligee that portion of the forfeited sum which exceed the actual liquidated damages incurred by the Obligee.

The Surety, for value received, hereby stipulates and agrees that the obligations of said Surety and its bond shall be in no way impaired or affected by an extension of the time within which the Obligee may accept such bid, and said Surety does hereby waive notice of any such extension.

IN WITNESS WHEREOF, the Principal and the Surety have hereunto set their hands and seals, and such of them as are corporations have caused their corporate seals to be hereto affixed and these presents to be signed by their proper officers, on the day and year set forth below.

Seal PRINCIPAL

Monona Plumbing & Fire Protection, Inc.

Name of Principal

Lisa Reiter

By

06-25-2020

Date

Lisa Reiter, HR manager

Name and Title

Seal SURETY

Fidelity and Deposit Company of Maryland

Name of Surety

David Zenobi

By

06-25-2020

Date

David Zenobi, Attorney-in-Fact

Name and Title

This certifies that I have been duly licensed as an agent for the above company in Wisconsin under National Provider No. 18708052 for the year 2020, and appointed as attorney in fact with authority to execute this bid bond and the payment and performance bond referred to above, which power of attorney has not been revoked.

06-25-2020

Date

David Zenobi

Agent Signature

PO Box 259408

Address

Madison, WI 53725-9408

City, State and Zip Code

608-252-9674

Telephone Number

NOTE TO SURETY & PRINCIPAL

The bid submitted which this bond guarantees shall be rejected if the following instrument is not attached to this bond:

Power of Attorney showing that the agent of Surety is currently authorized to execute bonds on behalf of the Surety, and in the amounts referenced above.

**ZURICH AMERICAN INSURANCE COMPANY
COLONIAL AMERICAN CASUALTY AND SURETY COMPANY
FIDELITY AND DEPOSIT COMPANY OF MARYLAND
POWER OF ATTORNEY**

KNOW ALL MEN BY THESE PRESENTS: That the ZURICH AMERICAN INSURANCE COMPANY, a corporation of the State of New York, the COLONIAL AMERICAN CASUALTY AND SURETY COMPANY, a corporation of the State of Illinois, and the FIDELITY AND DEPOSIT COMPANY OF MARYLAND a corporation of the State of Illinois (herein collectively called the "Companies"), by **Robert D. Murray, Vice President**, in pursuance of authority granted by Article V, Section 8, of the By-Laws of said Companies, which are set forth on the reverse side hereof and are hereby certified to be in full force and effect on the date hereof, do hereby nominate, constitute, and appoint, **Judith A. WALKER, Elizabeth MOSCA, David ZENOBI, Patrick A. MCKENNA and Brooke L. PARKER, all of Madison, Wisconsin**, Each, its true and lawful agent and Attorney-in-Fact, to make, execute, seal and deliver, for, and on its behalf as surety, and as its act and deed: any and all bonds and undertakings, **EXCEPT bonds on behalf of Independent Executors, Community Survivors and Community Guardians**, and the execution of such bonds or undertakings in pursuance of these presents, shall be as binding upon said Companies, as fully and amply, to all intents and purposes, as if they had been duly executed and acknowledged by the regularly elected officers of the ZURICH AMERICAN INSURANCE COMPANY at its office in New York, New York., the regularly elected officers of the COLONIAL AMERICAN CASUALTY AND SURETY COMPANY at its office in Owings Mills, Maryland., and the regularly elected officers of the FIDELITY AND DEPOSIT COMPANY OF MARYLAND at its office in Owings Mills, Maryland., in their own proper persons.

The said Vice President does hereby certify that the extract set forth on the reverse side hereof is a true copy of Article V, Section 8, of the By-Laws of said Companies and is now in force.

IN WITNESS WHEREOF, the said Vice-President has hereunto subscribed his/her names and affixed the Corporate Seals of the said ZURICH AMERICAN INSURANCE COMPANY, COLONIAL AMERICAN CASUALTY AND SURETY COMPANY, and FIDELITY AND DEPOSIT COMPANY OF MARYLAND, this 27th day of February, A.D. 2020.



ATTEST:
ZURICH AMERICAN INSURANCE COMPANY
COLONIAL AMERICAN CASUALTY AND SURETY COMPANY
FIDELITY AND DEPOSIT COMPANY OF MARYLAND

By: *Robert D. Murray*
Vice President

By: *Dawn E. Brown*
Secretary

**State of Maryland
County of Baltimore**

On this 27th day of February, A.D. 2020, before the subscriber, a Notary Public of the State of Maryland, duly commissioned and qualified, **Robert D. Murray, Vice President and Dawn E. Brown, Secretary** of the Companies, to me personally known to be the individuals and officers described in and who executed the preceding instrument, and acknowledged the execution of same, and being by me duly sworn, depose and saith, that he/she is the said officer of the Company aforesaid, and that the seals affixed to the preceding instrument are the Corporate Seals of said Companies, and that the said Corporate Seals and the signature as such officer were duly affixed and subscribed to the said instrument by the authority and direction of the said Corporations.

IN TESTIMONY WHEREOF, I have hereunto set my hand and affixed my Official Seal the day and year first above written.



Constance A. Dunn, Notary Public
My Commission Expires: July 9, 2023

EXTRACT FROM BY-LAWS OF THE COMPANIES

"Article V, Section 8, Attorneys-in-Fact. The Chief Executive Officer, the President, or any Executive Vice President or Vice President may, by written instrument under the attested corporate seal, appoint attorneys-in-fact with authority to execute bonds, policies, recognizances, stipulations, undertakings, or other like instruments on behalf of the Company, and may authorize any officer or any such attorney-in-fact to affix the corporate seal thereto; and may with or without cause modify or revoke any such appointment or authority at any time."

CERTIFICATE

I, the undersigned, Vice President of the ZURICH AMERICAN INSURANCE COMPANY, the COLONIAL AMERICAN CASUALTY AND SURETY COMPANY, and the FIDELITY AND DEPOSIT COMPANY OF MARYLAND, do hereby certify that the foregoing Power of Attorney is still in full force and effect on the date of this certificate; and I do further certify that Article V, Section 8, of the By- Laws of the Companies is still in force.

This Power of Attorney and Certificate may be signed by facsimile under and by authority of the following resolution of the Board of Directors of the ZURICH AMERICAN INSURANCE COMPANY at a meeting duly called and held on the 15th day of December 1998.

RESOLVED: "That the signature of the President or a Vice President and the attesting signature of a Secretary or an Assistant Secretary and the Seal of the Company may be affixed by facsimile on any Power of Attorney...Any such Power or any certificate thereof bearing such facsimile signature and seal shall be valid and binding on the Company."

This Power of Attorney and Certificate may be signed by facsimile under and by authority of the following resolution of the Board of Directors of the COLONIAL AMERICAN CASUALTY AND SURETY COMPANY at a meeting duly called and held on the 5th day of May, 1994, and the following resolution of the Board of Directors of the FIDELITY AND DEPOSIT COMPANY OF MARYLAND at a meeting duly called and held on the 10th day of May, 1990.

RESOLVED: "That the facsimile or mechanically reproduced seal of the company and facsimile or mechanically reproduced signature of any Vice-President, Secretary, or Assistant Secretary of the Company, whether made heretofore or hereafter, wherever appearing upon a certified copy of any power of attorney issued by the Company, shall be valid and binding upon the Company with the same force and effect as though manually affixed.

IN TESTIMONY WHEREOF, I have hereunto subscribed my name and affixed the corporate seals of the said Companies, this 25 day of June, 2020.



By: Brian M. Hodges
Vice President

TO REPORT A CLAIM WITH REGARD TO A SURETY BOND, PLEASE SUBMIT A COMPLETE DESCRIPTION OF THE CLAIM INCLUDING THE PRINCIPAL ON THE BOND, THE BOND NUMBER, AND YOUR CONTACT INFORMATION TO:

Zurich Surety Claims
1299 Zurich Way
Schaumburg, IL 60196-1056
www.reportsfclaims@zurichna.com
800-626-4577

SECTION H: AGREEMENT

THIS AGREEMENT made this 22nd day of July in the year Two Thousand and Twenty between MONONA PLUMBING AND FIRE PROTECTION, INC. hereinafter called the Contractor, and the City of Madison, Wisconsin, hereinafter called the City.

WHEREAS, the Common Council of the said City of Madison under the provisions of a resolution adopted JULY 21, 2020, and by virtue of authority vested in the said Council, has awarded to the Contractor the work of performing certain construction.

NOW, THEREFORE, the Contractor and the City, for the consideration hereinafter named, agree as follows:

1. **Scope of Work.** The Contractor shall, perform the construction, execution and completion of the following listed complete work or improvement in full compliance with the Plans, Specifications, Standard Specifications, Supplemental Specifications, Special Provisions and contract; perform all items of work covered or stipulated in the proposal; perform all altered or extra work; and shall furnish, unless otherwise provided in the contract, all materials, implements, machinery, equipment, tools, supplies, transportation, and labor necessary to the prosecution and completion of the work or improvements:

UW 26 BOOSTER PUMP UPGRADE CONTRACT NO. 8898

2. **Completion Date/Contract Time.** Construction work must begin within seven (7) calendar days after the date appearing on mailed written notice to do so shall have been sent to the Contractor and shall be carried on at a rate so as to secure full completion SEE SPECIAL PROVISIONS, the rate of progress and the time of completion being essential conditions of this Agreement.
3. **Contract Price.** The City shall pay to the Contractor at the times, in the manner and on the conditions set forth in said specifications, the sum of SEVENTY-ONE THOUSAND TWO HUNDRED FIFTY-THREE AND NO/100 (\$71,253.00) Dollars being the amount bid by such Contractor and which was awarded to him/her as provided by law.
4. **Affirmative Action.** In the performance of the services under this Agreement the Contractor agrees not to discriminate against any employee or applicant because of race, religion, marital status, age, color, sex, disability, national origin or ancestry, income level or source of income, arrest record or conviction record, less than honorable discharge, physical appearance, sexual orientation, gender identity, political beliefs, or student status. The Contractor further agrees not to discriminate against any subcontractor or person who offers to subcontract on this contract because of race, religion, color, age, disability, sex, sexual orientation, gender identity or national origin.

The Contractor agrees that within thirty (30) days after the effective date of this agreement, the Contractor will provide to the City Affirmative Action Division certain workforce utilization statistics, using a form to be furnished by the City.

If the contract is still in effect, or if the City enters into a new agreement with the Contractor, within one year after the date on which the form was required to be provided, the Contractor will provide updated workforce information using a second form, also to be furnished by the City. The second form will be submitted to the City Affirmative Action Division no later than one year after the date on which the first form was required to be provided.

The Contractor further agrees that, for at least twelve (12) months after the effective date of this contract, it will notify the City Affirmative Action Division of each of its job openings at facilities in Dane County for which applicants not already employees of the Contractor are to be considered. The notice will include a job description, classification, qualification and application procedures and deadlines. The Contractor agrees to interview and consider candidates referred by the Affirmative Action Division if the candidate meets the minimum qualification standards established

by the Contractor, and if the referral is timely. A referral is timely if it is received by the Contractor on or before the date started in the notice.

Articles of Agreement
Article I

The Contractor shall take affirmative action in accordance with the provisions of this contract to insure that applicants are employed, and that employees are treated during employment without regard to race, religion, color, age, marital status, disability, sex, sexual orientation, gender identity or national origin and that the employer shall provide harassment free work environment for the realization of the potential of each employee. Such action shall include, but not be limited to, the following: employment, upgrading, demotion or transfer, recruitment or recruitment advertising, layoff or termination, rates of pay or other forms of compensation and selection for training including apprenticeship insofar as it is within the control of the Contractor. The Contractor agrees to post in conspicuous places available to employees and applicants notices to be provided by the City setting out the provisions of the nondiscrimination clauses in this contract.

Article II

The Contractor shall in all solicitations or advertisements for employees placed by or on behalf of the Contractors state that all qualified or qualifiable applicants will be employed without regard to race, religion, color, age, marital status, disability, sex, sexual orientation, gender identity or national origin.

Article III

The Contractor shall send to each labor union or representative of workers with which it has a collective bargaining agreement or other contract or understanding a notice to be provided by the City advising the labor union or worker's representative of the Contractor's equal employment opportunity and affirmative action commitments. Such notices shall be posted in conspicuous places available to employees and applicants for employment.

Article V

The Contractor agrees that it will comply with all provisions of the Affirmative Action Ordinance of the City of Madison, including the contract compliance requirements. The Contractor agrees to submit the model affirmative action plan for public works contractors in a form approved by the Affirmative Action Division Manager.

Article VI

The Contractor will maintain records as required by Section 39.02(9)(f) of the Madison General Ordinances and will provide the City Affirmative Action Division with access to such records and to persons who have relevant and necessary information, as provided in Section 39.02(9)(f). The City agrees to keep all such records confidential, except to the extent that public inspection is required by law.

Article VII

In the event of the Contractor's or subcontractor's failure to comply with the Equal Employment Opportunity and Affirmative Action Provisions of this contract or Section 39.03 and 39.02 of the Madison General Ordinances, it is agreed that the City at its option may do any or all of the following:

1. Cancel, terminate or suspend this Contract in whole or in part.

2. Declare the Contractor ineligible for further City contracts until the Affirmative Action requirements are met.
3. Recover on behalf of the City from the prime Contractor 0.5 percent of the contract award price for each week that such party fails or refuses to comply, in the nature of liquidated damages, but not to exceed a total of five percent (5%) of the contract price, or ten thousand dollars (\$10,000), whichever is less. Under public works contracts, if a subcontractor is in noncompliance, the City may recover liquidated damages from the prime Contractor in the manner described above. The preceding sentence shall not be construed to prohibit a prime Contractor from recovering the amount of such damage from the non-complying subcontractor.

Article VIII

The Contractor shall include the above provisions of this contract in every subcontract so that such provisions will be binding upon each subcontractor. The Contractor shall take such action with respect to any subcontractor as necessary to enforce such provisions, including sanctions provided for noncompliance.

Article IX

The Contractor shall allow the maximum feasible opportunity to small business enterprises to compete for any subcontracts entered into pursuant to this contract. (In federally funded contracts the terms "DBE, MBE and WBE" shall be substituted for the term "small business" in this Article.)

5. Substance Abuse Prevention Program Required. Prior to commencing work on the Contract, the Contractor, and any Subcontractor, shall have in place a written program for the prevention of substance abuse among its employees as required under Wis. Stat. Sec. 103.503.
6. **Contractor Hiring Practices.**

Ban the Box - Arrest and Criminal Background Checks. (Sec. 39.08, MGO)

This provision applies to all prime contractors on contracts entered into on or after January 1, 2016, and all subcontractors who are required to meet prequalification requirements under MGO 33.07(7)(I), MGO as of the first time they seek or renew pre-qualification status on or after January 1, 2016. The City will monitor compliance of subcontractors through the pre-qualification process.

- a. **Definitions.** For purposes of this section, "Arrest and Conviction Record" includes, but is not limited to, information indicating that a person has been questioned, apprehended, taken into custody or detention, held for investigation, arrested, charged with, indicted or tried for any felony, misdemeanor or other offense pursuant to any law enforcement or military authority.

"Conviction record" includes, but is not limited to, information indicating that a person has been convicted of a felony, misdemeanor or other offense, placed on probation, fined, imprisoned or paroled pursuant to any law enforcement or military authority.

"Background Check" means the process of checking an applicant's arrest and conviction record, through any means.

- b. **Requirements.** For the duration of this Contract, the Contractor shall:

1. Remove from all job application forms any questions, check boxes, or other inquiries regarding an applicant's arrest and conviction record, as defined herein.

2. Refrain from asking an applicant in any manner about their arrest or conviction record until after conditional offer of employment is made to the applicant in question.
3. Refrain from conducting a formal or informal background check or making any other inquiry using any privately or publicly available means of obtaining the arrest or conviction record of an applicant until after a conditional offer of employment is made to the applicant in question.
4. Make information about this ordinance available to applicants and existing employees, and post notices in prominent locations at the workplace with information about the ordinance and complaint procedure using language provided by the City.
5. Comply with all other provisions of Sec. 39.08, MGO.

c. Exemptions: This section shall not apply when:

1. Hiring for a position where certain convictions or violations are a bar to employment in that position under applicable law, or
2. Hiring a position for which information about criminal or arrest record, or a background check is required by law to be performed at a time or in a manner that would otherwise be prohibited by this ordinance, including a licensed trade or profession where the licensing authority explicitly authorizes or requires the inquiry in question.

To be exempt, Contractor has the burden of demonstrating that there is an applicable law or regulation that requires the hiring practice in question, if so, the contractor is exempt from all of the requirements of this ordinance for the position(s) in question.

**UW 26 BOOSTER PUMP UPGRADE
CONTRACT NO. 8898**

IN WITNESS WHEREOF, the Contractor has hereunto set his/her hand and seal and the City has caused this contract to be sealed with its corporate seal and to be executed by its Mayor and City Clerk on the dates written below.

Countersigned:

**MONONA PLUMBING AND FIRE
PROTECTION, INC.**

 7/22/20
Witness Date

Kara Kraemer 7/22/20
Witness Date

Company Name _____
 7/22
President Date

 7/22
Secretary Date

CITY OF MADISON, WISCONSIN

Provisions have been made to pay the liability that will accrue under this contract.

Approved as to form:

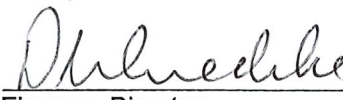
 8/03/2020
Finance Director Date

 8/4/20
Witness Date

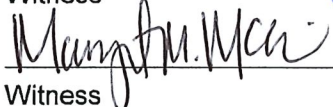
 7/30/20
Witness Date

 8/14/20
City Attorney Date

 8/7/2020
Mayor Date

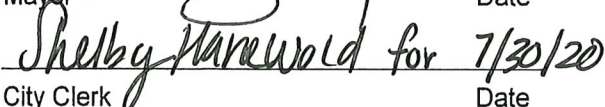
 for 7/30/20
City Clerk Date

SECTION I: PAYMENT AND PERFORMANCE BOND

LET ALL KNOW BY THESE DOCUMENTS PRESENTED, that we **MONONA PLUMBING AND FIRE PROTECTION, INC.** as principal, and Fidelity and Deposit Company of Maryland Company of Illinois as surety, are held and firmly bound unto the City of Madison, Wisconsin, in the sum of **SEVENTY-ONE THOUSAND TWO HUNDRED FIFTY-THREE AND NO/100 (\$71,253.00)** Dollars, lawful money of the United States, for the payment of which sum to the City of Madison, we hereby bind ourselves and our respective executors and administrators firmly by these presents.

The condition of this Bond is such that if the above bounden shall on his/her part fully and faithfully perform all of the terms of the Contract entered into between him/herself and the City of Madison for the construction of:

UW 26 BOOSTER PUMP UPGRADE
CONTRACT NO. 8898

in Madison, Wisconsin, and shall pay all claims for labor performed and material furnished in the prosecution of said work, and save the City harmless from all claims for damages because of negligence in the prosecution of said work, and shall save harmless the said City from all claims for compensation (under Chapter 102, Wisconsin Statutes) of employees and employees of subcontractor, then this Bond is to be void, otherwise of full force, virtue and effect.

Signed and sealed this 22 day of July, 2020

Countersigned:

MONONA PLUMBING AND FIRE PROTECTION, INC.
Company Name (Principal)

Kara Kraemer
Witness

[Signature]
President Seal

Secretary

Approved as to form:

Fidelity and Deposit Company of Maryland
Surety Seal
 Salary Employee Commission

Michael Haas
City Attorney

By [Signature]
Attorney-in-Fact, Patrick A McKenna

This certifies that I have been duly licensed as an agent for the above company in Wisconsin under National Producer Number 650765 for the year 2020, and appointed as attorney-in-fact with authority to execute this payment and performance bond which power of attorney has not been revoked.

July 22, 2020
Date

[Signature]
Agent Signature, Patrick A McKenna

**ZURICH AMERICAN INSURANCE COMPANY
COLONIAL AMERICAN CASUALTY AND SURETY COMPANY
FIDELITY AND DEPOSIT COMPANY OF MARYLAND
POWER OF ATTORNEY**

KNOW ALL MEN BY THESE PRESENTS: That the ZURICH AMERICAN INSURANCE COMPANY, a corporation of the State of New York, the COLONIAL AMERICAN CASUALTY AND SURETY COMPANY, a corporation of the State of Illinois, and the FIDELITY AND DEPOSIT COMPANY OF MARYLAND a corporation of the State of Illinois (herein collectively called the "Companies"), by **Robert D. Murray, Vice President**, in pursuance of authority granted by Article V, Section 8, of the By-Laws of said Companies, which are set forth on the reverse side hereof and are hereby certified to be in full force and effect on the date hereof, do hereby nominate, constitute, and appoint, **Judith A. WALKER, Elizabeth MOSCA, David ZENOBI, Patrick A. MCKENNA and Brooke L. PARKER, all of Madison, Wisconsin**, Each, its true and lawful agent and Attorney-in-Fact, to make, execute, seal and deliver, for, and on its behalf as surety, and as its act and deed: any and all bonds and undertakings, **EXCEPT bonds on behalf of Independent Executors, Community Survivors and Community Guardians**, and the execution of such bonds or undertakings in pursuance of these presents, shall be as binding upon said Companies, as fully and amply, to all intents and purposes, as if they had been duly executed and acknowledged by the regularly elected officers of the ZURICH AMERICAN INSURANCE COMPANY at its office in New York, New York., the regularly elected officers of the COLONIAL AMERICAN CASUALTY AND SURETY COMPANY at its office in Owings Mills, Maryland., and the regularly elected officers of the FIDELITY AND DEPOSIT COMPANY OF MARYLAND at its office in Owings Mills, Maryland., in their own proper persons.

The said Vice President does hereby certify that the extract set forth on the reverse side hereof is a true copy of Article V, Section 8, of the By-Laws of said Companies and is now in force.

IN WITNESS WHEREOF, the said Vice-President has hereunto subscribed his/her names and affixed the Corporate Seals of the said **ZURICH AMERICAN INSURANCE COMPANY, COLONIAL AMERICAN CASUALTY AND SURETY COMPANY, and FIDELITY AND DEPOSIT COMPANY OF MARYLAND**, this 27th day of February, A.D. 2020.



**ATTEST:
ZURICH AMERICAN INSURANCE COMPANY
COLONIAL AMERICAN CASUALTY AND SURETY COMPANY
FIDELITY AND DEPOSIT COMPANY OF MARYLAND**

By: *Robert D. Murray*
Vice President

By: *Dawn E. Brown*
Secretary

**State of Maryland
County of Baltimore**

On this 27th day of February, A.D. 2020, before the subscriber, a Notary Public of the State of Maryland, duly commissioned and qualified, **Robert D. Murray, Vice President and Dawn E. Brown, Secretary** of the Companies, to me personally known to be the individuals and officers described in and who executed the preceding instrument, and acknowledged the execution of same, and being by me duly sworn, deposed and saith, that he/she is the said officer of the Company aforesaid, and that the seals affixed to the preceding instrument are the Corporate Seals of said Companies, and that the said Corporate Seals and the signature as such officer were duly affixed and subscribed to the said instrument by the authority and direction of the said Corporations.

IN TESTIMONY WHEREOF, I have hereunto set my hand and affixed my Official Seal the day and year first above written.



Constance A. Dunn, Notary Public
My Commission Expires: July 9, 2023

EXTRACT FROM BY-LAWS OF THE COMPANIES

"Article V, Section 8, Attorneys-in-Fact. The Chief Executive Officer, the President, or any Executive Vice President or Vice President may, by written instrument under the attested corporate seal, appoint attorneys-in-fact with authority to execute bonds, policies, recognizances, stipulations, undertakings, or other like instruments on behalf of the Company, and may authorize any officer or any such attorney-in-fact to affix the corporate seal thereto; and may with or without cause modify or revoke any such appointment or authority at any time."

CERTIFICATE

I, the undersigned, Vice President of the ZURICH AMERICAN INSURANCE COMPANY, the COLONIAL AMERICAN CASUALTY AND SURETY COMPANY, and the FIDELITY AND DEPOSIT COMPANY OF MARYLAND, do hereby certify that the foregoing Power of Attorney is still in full force and effect on the date of this certificate; and I do further certify that Article V, Section 8, of the By- Laws of the Companies is still in force.

This Power of Attorney and Certificate may be signed by facsimile under and by authority of the following resolution of the Board of Directors of the ZURICH AMERICAN INSURANCE COMPANY at a meeting duly called and held on the 15th day of December 1998.

RESOLVED: "That the signature of the President or a Vice President and the attesting signature of a Secretary or an Assistant Secretary and the Seal of the Company may be affixed by facsimile on any Power of Attorney...Any such Power or any certificate thereof bearing such facsimile signature and seal shall be valid and binding on the Company."

This Power of Attorney and Certificate may be signed by facsimile under and by authority of the following resolution of the Board of Directors of the COLONIAL AMERICAN CASUALTY AND SURETY COMPANY at a meeting duly called and held on the 5th day of May, 1994, and the following resolution of the Board of Directors of the FIDELITY AND DEPOSIT COMPANY OF MARYLAND at a meeting duly called and held on the 10th day of May, 1990.

RESOLVED: "That the facsimile or mechanically reproduced seal of the company and facsimile or mechanically reproduced signature of any Vice-President, Secretary, or Assistant Secretary of the Company, whether made heretofore or hereafter, wherever appearing upon a certified copy of any power of attorney issued by the Company, shall be valid and binding upon the Company with the same force and effect as though manually affixed.

IN TESTIMONY WHEREOF, I have hereunto subscribed my name and affixed the corporate seals of the said Companies, this 22 day of July, 2020.



Brian M. Hodges

By: Brian M. Hodges
Vice President

TO REPORT A CLAIM WITH REGARD TO A SURETY BOND, PLEASE SUBMIT A COMPLETE DESCRIPTION OF THE CLAIM INCLUDING THE PRINCIPAL ON THE BOND, THE BOND NUMBER, AND YOUR CONTACT INFORMATION TO:

Zurich Surety Claims
1299 Zurich Way
Schaumburg, IL 60196-1056
www.reportsfclaims@zurichna.com
800-626-4577



MADISON WATER UTILITY

UNIT WELL 26 BOOSTER PUMP #1 UPGRADE

MAY 28, 2020

CITY PROJECT NO. 12661-86-150
 CONTRACT NO. 8898

INDEX OF SHEETS

SHEET NO.	W-1	APPURTENANCE SCHEDULE
SHEET NO.	W-2	EXISTING FLOOR PLAN
SHEET NO.	W-3	EXISTING PIPING PLAN
SHEET NO.	W-4	EXISTING PIPING SECTION
SHEET NO.	W-5	DEMOLITION & SEQUENCING PLAN
SHEET NO.	W-6	PROPOSED PIPING PLAN
SHEET NO.	W-7	PROPOSED PIPING SECTION
SHEET NO.	W-8	PHOTOS
SHEET NO.	W-9	PHOTOS & DETAILS

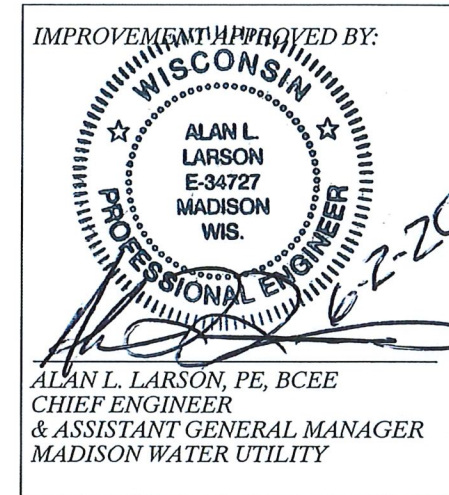

PROJECT LOCATION
 910 S. HIGH POINT RD.

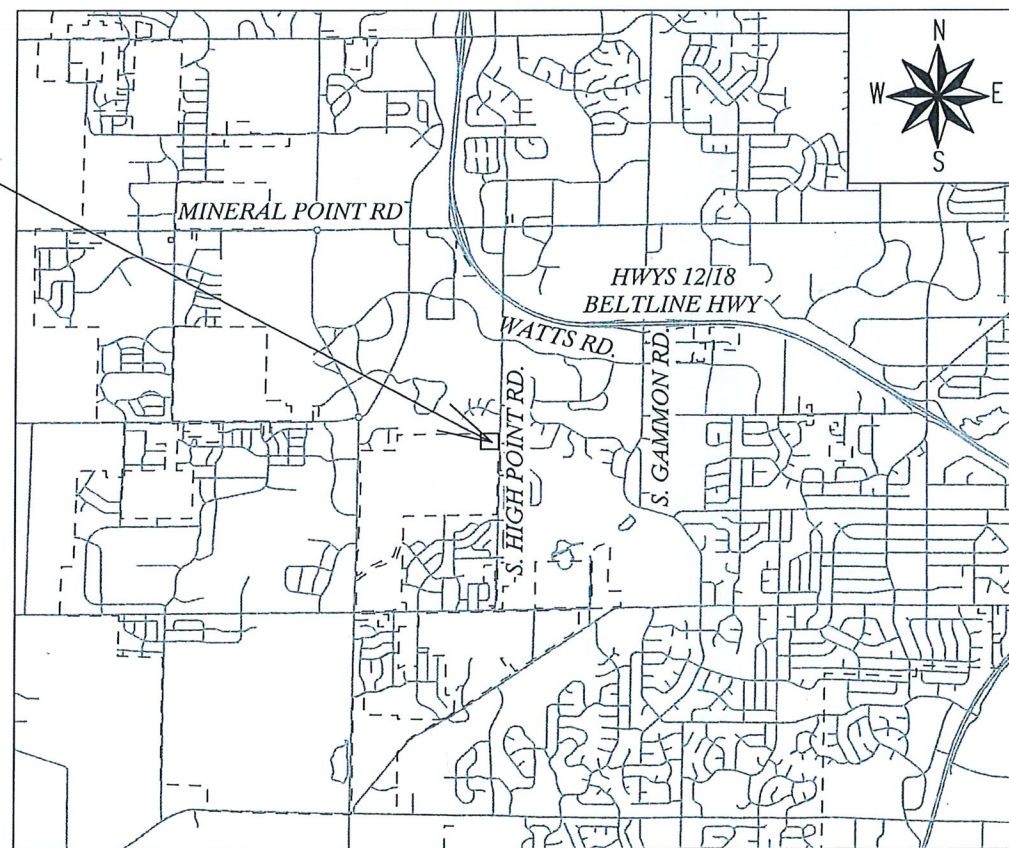

GENERAL NOTES

- UNLESS OTHERWISE SPECIFIED, ALL CONSTRUCTION SHALL CONFORM TO CITY OF MADISON STANDARD SPECIFICATIONS FOR PUBLIC WORKS CONSTRUCTION 2020 EDITION. SEE [HTTPS://WWW.CITYOFMADISON.COM/BUSINESS/PW/SPECS.CFM](https://www.cityofmadison.com/business/pw/specs.cfm)
- PIPE MATERIAL SHALL BE CLASS 52 DUCTILE IRON PIPE.
- SEE SEQUENCE OF DEMOLITION AND CONSTRUCTION ON SHEET W-5. WELL 26 SHALL NOT BE OFFLINE (DOWN) FOR MORE THAN SIX HOURS WITHOUT MADISON WATER UTILITY (MWU) WRITTEN APPROVAL.
- REMOVAL AND PROPER DISPOSAL OF THE OLD PUMP, AND INSTALLATION OF A NEW PUMP IS PART OF THIS CONTRACT. THE NEW PUMP AND UNIT ELECTRICAL WIRING ARE PROVIDED BY MWU. SEE SUGGESTED SEQUENCE OF DEMOLITION AND CONSTRUCTION ON SHEET W-5 FOR ADDITIONAL NOTES.
- NEW PUMP IS STORED AT THE UTILITY OPERATIONS CENTER AT 110 S. PATERSON ST. ARRANGE WITH UTILITY TO PICK UP PUMP AND TRANSPORT TO JOB SITE.
- ALL REQUIRED PERMITS ARE THE RESPONSIBILITY OF THE CONTRACTOR.
- CONTRACTOR IS REQUIRED TO MAINTAIN A SAFE WORKSPACE THROUGHOUT THE PROJECT.
- WORK SHALL COMMENCE NO MORE THAN 30 DAYS AFTER EXECUTION OF THE CONTRACT AND RECEIPT OF THE START WORK LETTER.
- PROJECT DURATION IS 30 CALENDAR DAYS FROM START OF WORK.

PLOT SCALE: 1" = 1'

PLOT NAME: ---

REV. DATE: 5/27/2020 1:04 PM

ORIGINATOR: CITY OF MADISON

APURTENANCE SCHEDULE

INSPECTOR: MWU
 CHECKED BY: A.L.L.

DRAWN BY: D.A.R.
 DATE: 5/27/2020

NUMBER	SIZE	TYPE	DISPOSITION	NORMAL POSITION	FUNCTION	NOTES
V-1	12"	BUTTERFLY	EXISTING	OPEN	DEEP WELL ISOLATION	
V-2	12"	BUTTERFLY	REPLACE	OPEN	RESERVOIR BYPASS	REPLACE WITH 12" WAFER STYLE BUTTERFLY VALVE WITH SPACER AS REQUIRED
V-3	12"	BUTTERFLY	EXISTING	OPEN	RESERVOIR ISOLATION	
V-4	24"	BUTTERFLY	EXISTING	OPEN	RESERVOIR ISOLATION	
V-5	24"	BUTTERFLY	EXISTING	OPEN	SYSTEM ISOLATION	
V-6	10"	GATE	REPLACE	OPEN	PUMP ISOLATION	REPLACE WITH 10" FLANGED GATE VALVE
V-7	8"	BUTTERFLY	REMOVE	OPEN	PUMP ISOLATION	
V-8	14"	GATE	EXISTING	OPEN	PUMP ISOLATION	
V-9	10"	BUTTERFLY	EXISTING	OPEN	PUMP ISOLATION	PROVIDE SPACER AS REQUIRED TO ALIGN WITH NEW PIPING
V-10	12"	BUTTERFLY	NEW	OPEN	PUMP ISOLATION	REPLACE WITH 12" FLANGED BUTTERFLY VALVE
V-11	12"	BUTTERFLY	EXISTING	OPEN	SYSTEM ISOLATION	
V-12	12"	BUTTERFLY	NEW	OPEN	RESERVOIR ISOLATION/PUMP SUCTION	
CV-1	12"	CHECK VALVE	EXISTING	-	BACKFLOW AT DEEP WELL PUMP	
CV-2	8"	CHECK VALVE	REPLACE	-	PREVENT BACKFLOW AT BOOSTER PUMP #1	REPLACE WITH 6" CHECK VALVE
CV-3	10"	CHECK VALVE	EXISTING	-	PREVENT BACKFLOW AT BOOSTER PUMP #2	
M-1	12"	METER	EXISTING	-	METERS DEEP WELL PUMP DISCHARGE	
M-2	12"	METER	EXSITING	-	METERS FLOW TO ELEVATED RESERVOIR	

GENERAL NOTES

- CHECK VALVES SHALL BE A FLANGED SWING CHECK VALVE WITH OUTSIDE LEVER AND WEIGHT EQUIPPED WITH AN AIR-CUSHION CHAMBER TO CUSHION THE CLOSING OF THE VALVE DISC. THE VALVE SHALL BE MANUFACTURED IN ACCORDANCE WITH AWWA C508. CHECK VALVES SHALL BE MANUFACTURED BY GA INDUSTRIES OR APPROVED EQUIVALENT.
- BUTTERFLY VALVES SHALL BE AWWA C504, FLANGED SHORT BODY (EXCEPT WHERE NOTED OTHERWISE), CLASS 150B, EQUIPPED WITH STAINLESS STEEL SHAFT, TOP-MOUNTED HANDWHEEL OPERATORS AND CAST IRON VALVE DISK, BUTTERFLY VALVES SHALL BE MANUFACTURED BY KENNEDY OR MUELLER.
- GATE VALVES SHALL BE RESILIENT WEDGE DESIGN PER AWWA C509, FLANGED AND EQUIPPED WITH HANDWHEEL OPERATOR. GATE VALVES SHALL BE MANUFACTURED BY KENNEDY, MUELLER OR CLOW.

PLOT SCALE: 1" = 40'

PLOT NAME:

REV. DATE:

ORIGINATOR: CITY_OF_MADISON_WATER_UTILITY

EXISTING FLOOR PLAN

INSPECTOR: MWU
 CHECKED BY: A.L.L.

DRAWN BY: D.A.R.
 DATE: 5/27/2020

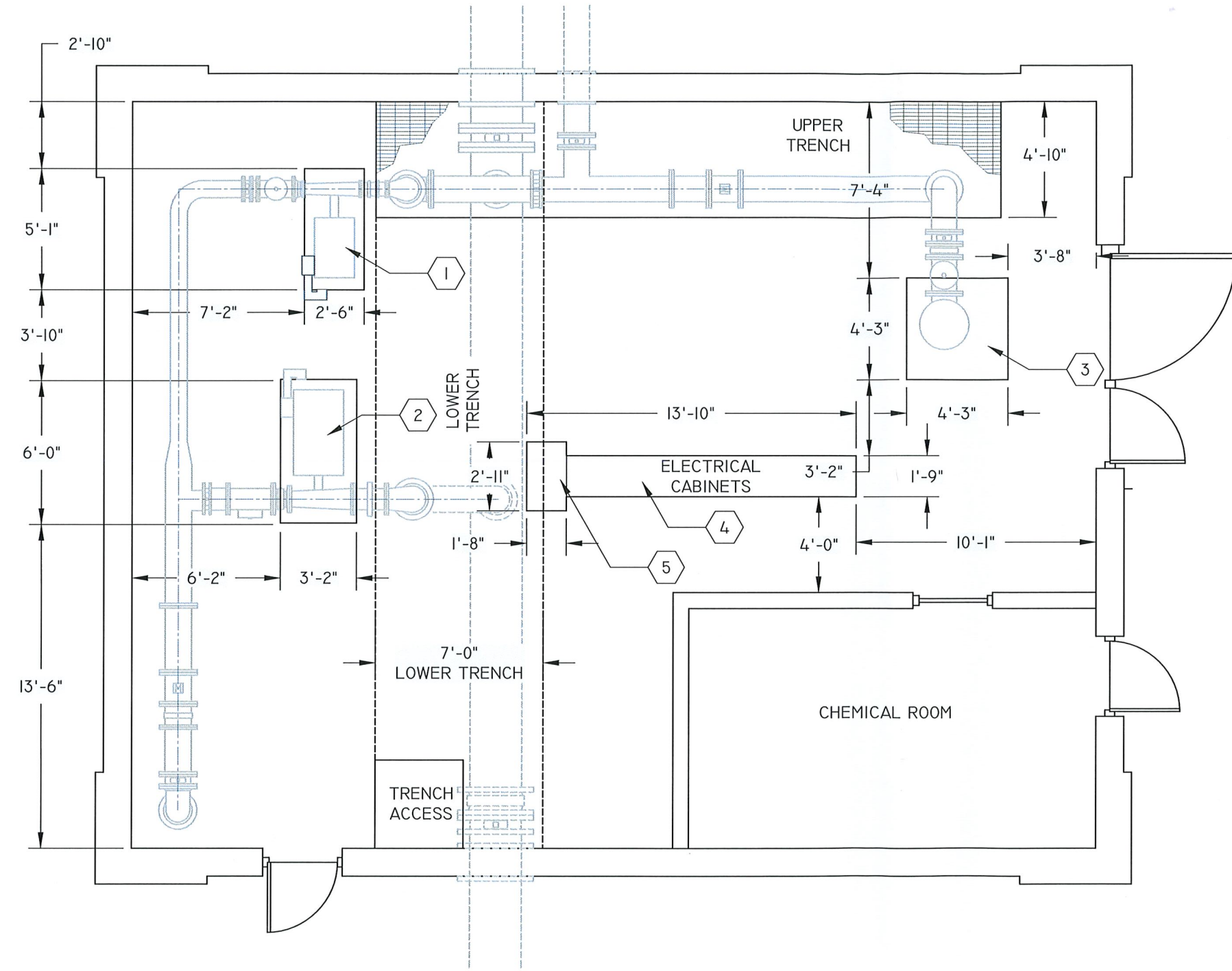

KEYED NOTES

1. CONCRETE BASE FOR BOOSTER PUMP #1, 2'-5" HEIGHT ABOVE FLOOR
2. CONCRETE BASE FOR BOOSTER PUMP #2, 2'-2" HEIGHT ABOVE FLOOR
3. CONCRETE BASE FOR DEEP WELL PUMP, 1'-0"± HEIGHT ABOVE FLOOR
4. ELECTRICAL CABINET 7'-8" HEIGHT ABOVE FLOOR
5. ELECTRICAL CABINET, 6'-2" HEIGHT ABOVE FLOOR
6. VERIFY ALL DIMENSIONS

PLOT SCALE: 1" = 4'

PLOT NAME:

REV. DATE:

ORIGINATOR: CITY_OF_MADISON_WATER_UTILITY

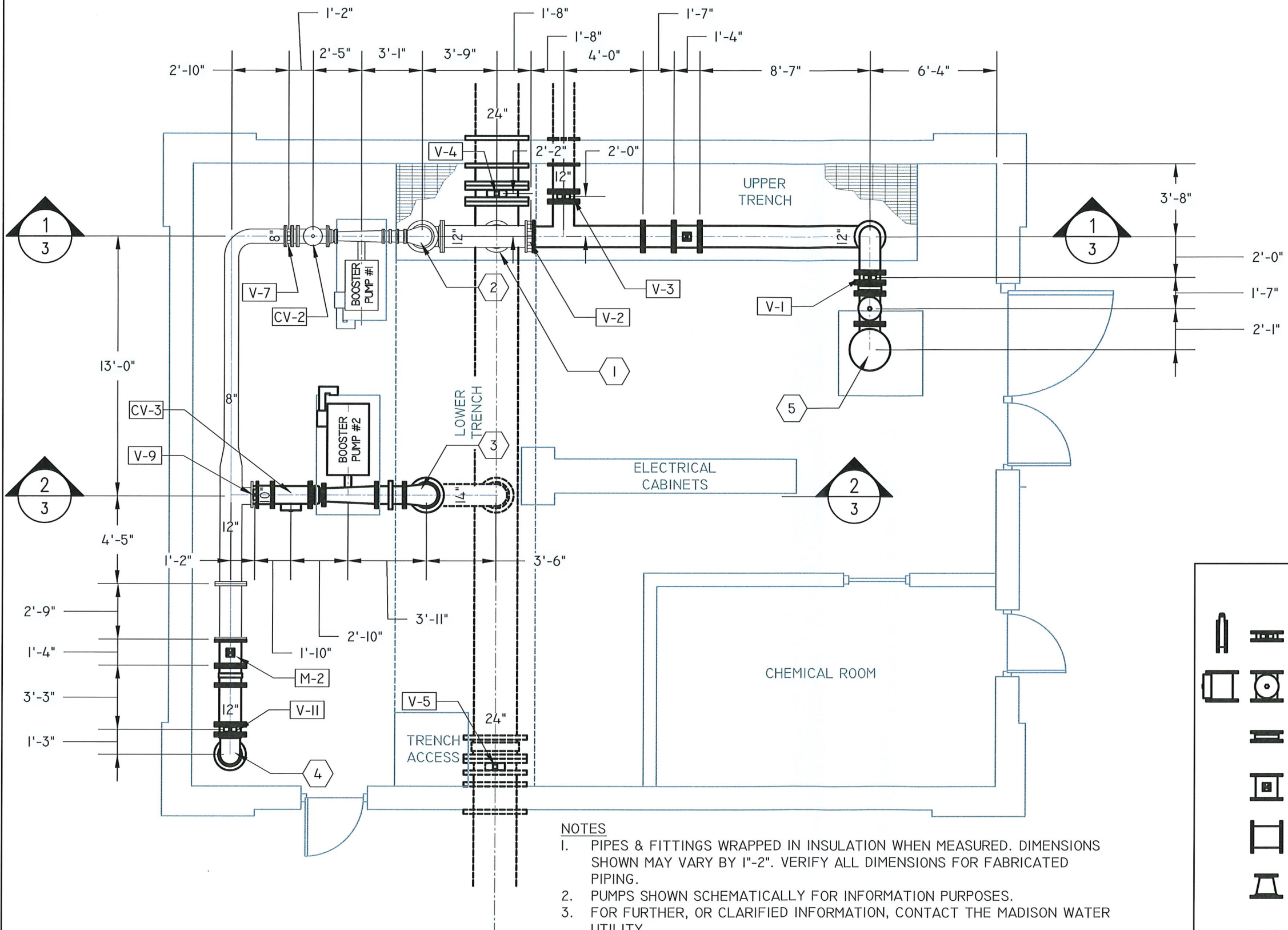

- KEYED NOTES**
- 12-IN X 12-IN VERTICAL TEE (BRANCH DOWN)
 - 6-IN X 10-IN FLANGED 90° REDUCING BEND (VERTICAL DOWN)
 - 10-IN X 14-IN FLANGED 90° REDUCING BEND (VERTICAL DOWN)
 - 12-IN X 12-IN VERTICAL BEND
 - DEEP WELL PUMP



LEGEND

	- BUTTERFLY VALVE
	- CHECK VALVE
	- EXPANSION JOINT, FLEXIBLE COUPLING
	- METER
	- FLANGED PIPE SECTION, PIPE DIAMETER
	- REDUCER
V-4 - VALVE NUMBER, REFER TO SEQUENCE OF DEMOLITION AND CONSTRUCTION, SHEET W-4	

- NOTES**
- PIPES & FITTINGS WRAPPED IN INSULATION WHEN MEASURED. DIMENSIONS SHOWN MAY VARY BY 1"-2". VERIFY ALL DIMENSIONS FOR FABRICATED PIPING.
 - PUMPS SHOWN SCHEMATICALLY FOR INFORMATION PURPOSES.
 - FOR FURTHER, OR CLARIFIED INFORMATION, CONTACT THE MADISON WATER UTILITY.
 - EXISTING PIPE IS FABRICATED WELDED STEEL
 - SEE PHOTOS ON SHEET 7/8 FOR ADDITIONAL DETAIL.
 - VERIFY ALL DIMENSIONS

PLOT SCALE: 1" = 40'
 PLOT NAME: _____
 REV. DATE: _____
 ORIGINATOR: CITY_OF_MADISON_WATER_UTILITY

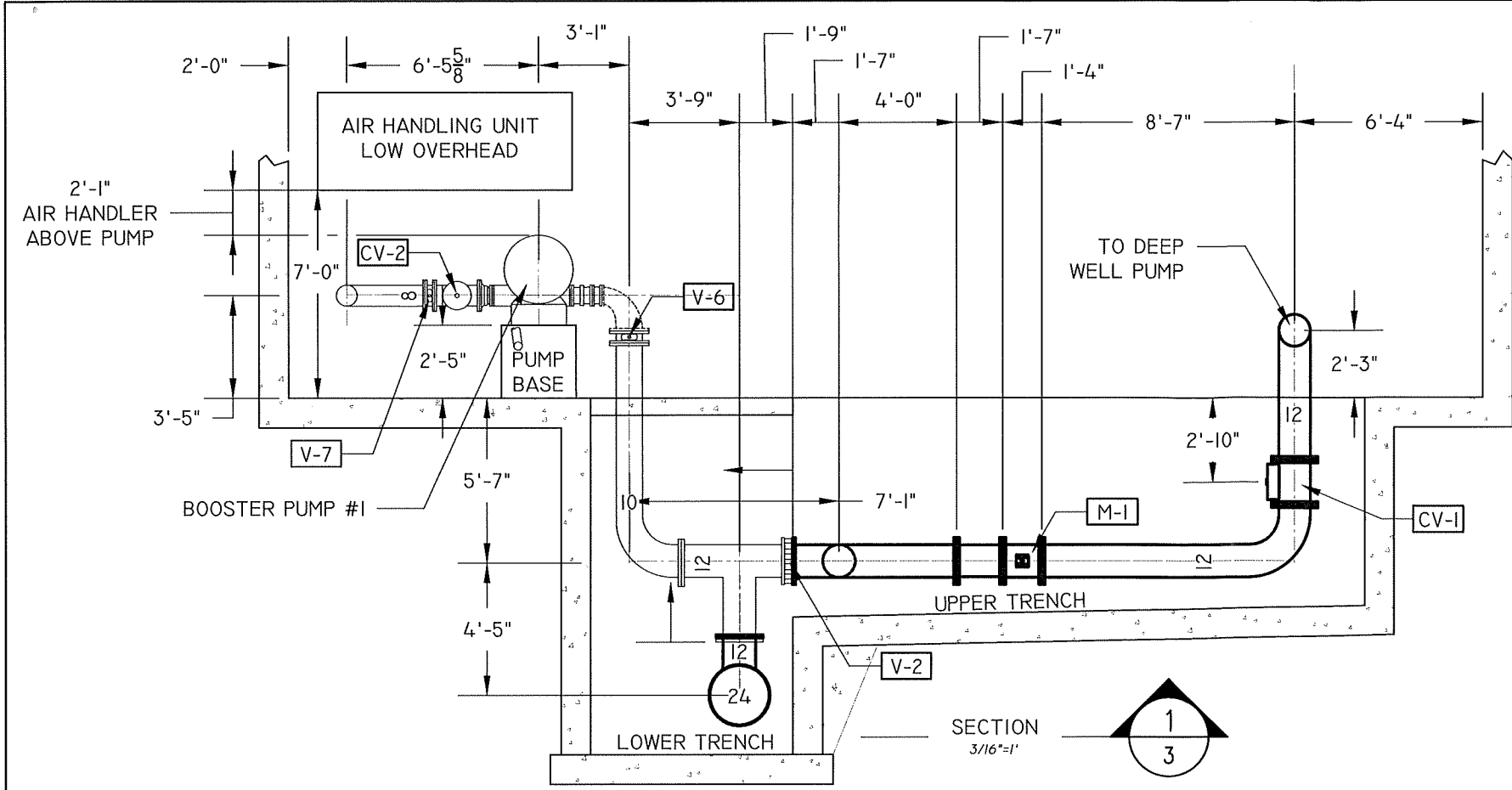

SECTION
3/16"=1'

NOTES
1. VERIFY ALL DIMENSIONS

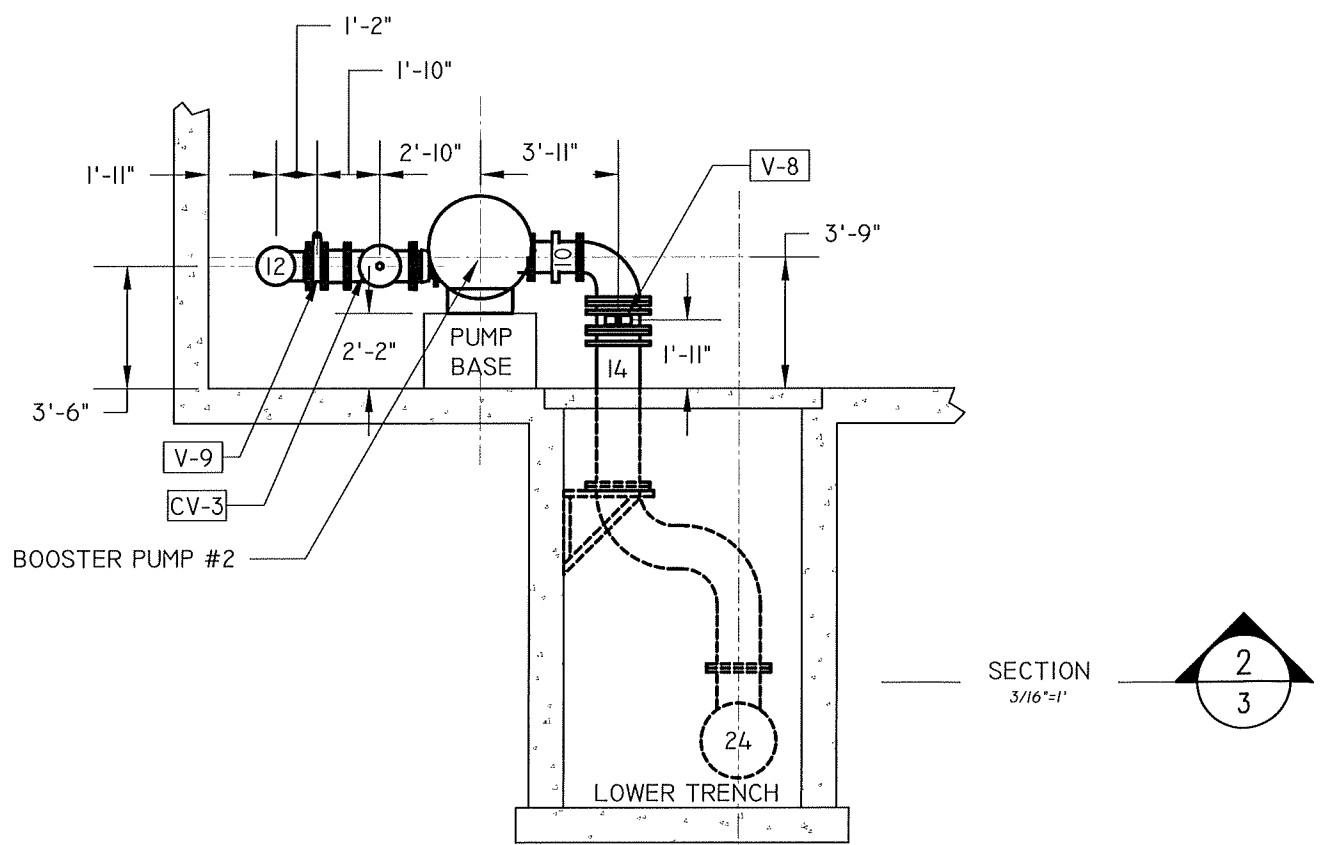

LEGEND

- BUTTERFLY VALVE
- CHECK VALVE
- EXPANSION JOINT, FLEXIBLE COUPLING
- METER
- FLANGED PIPE SECTION, PIPE DIAMETER
- REDUCER
- V-4 - VALVE NUMBER, REFER TO SEQUENCE OF DEMOLITION AND CONSTRUCTION, SHEET W-4

PLOT SCALE: 1" = 40'

PLOT NAME:

REV. DATE:

ORIGINATOR: CITY_OF_MADISON_WATER_UTILITY

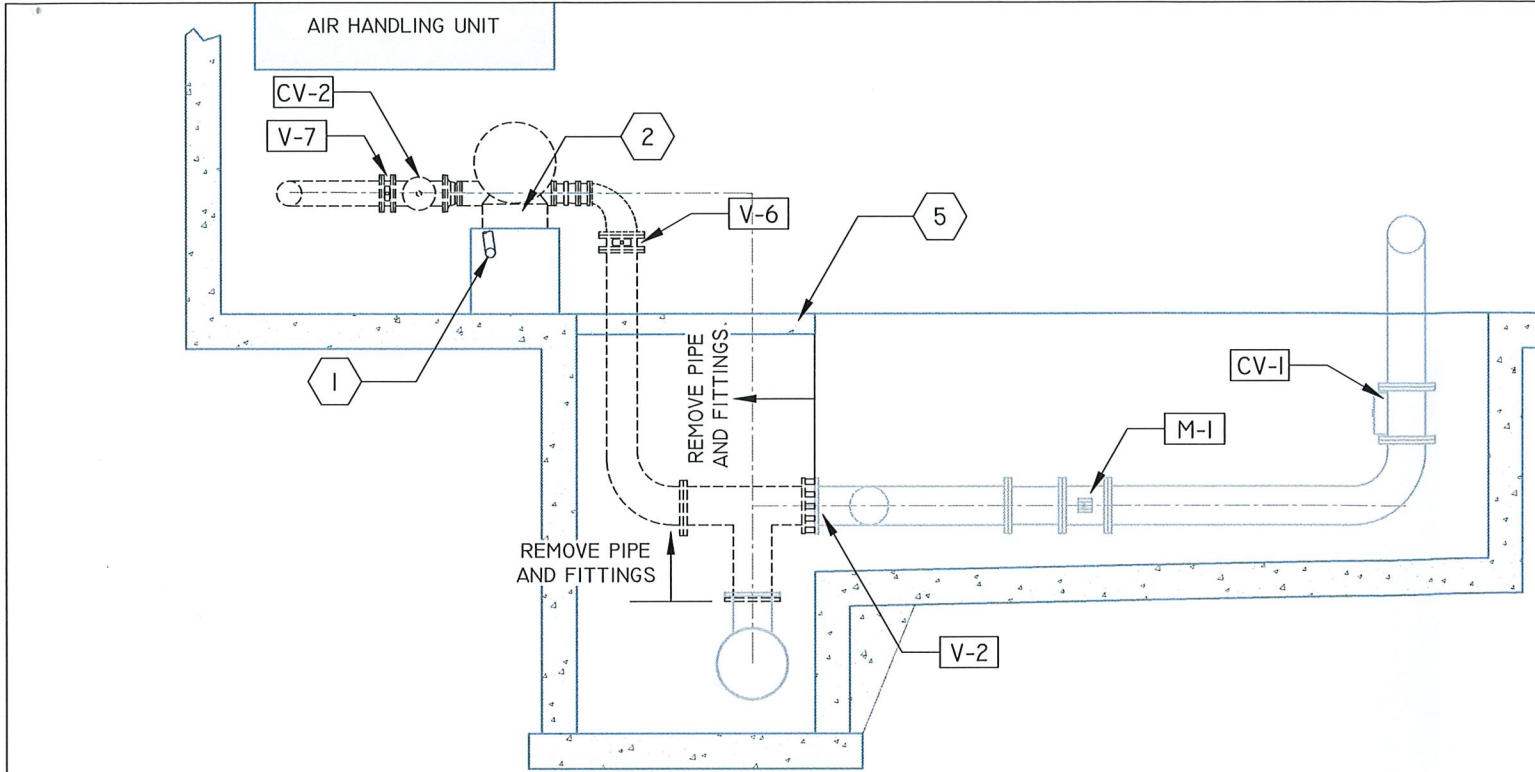

SECTION
3/16"=1'

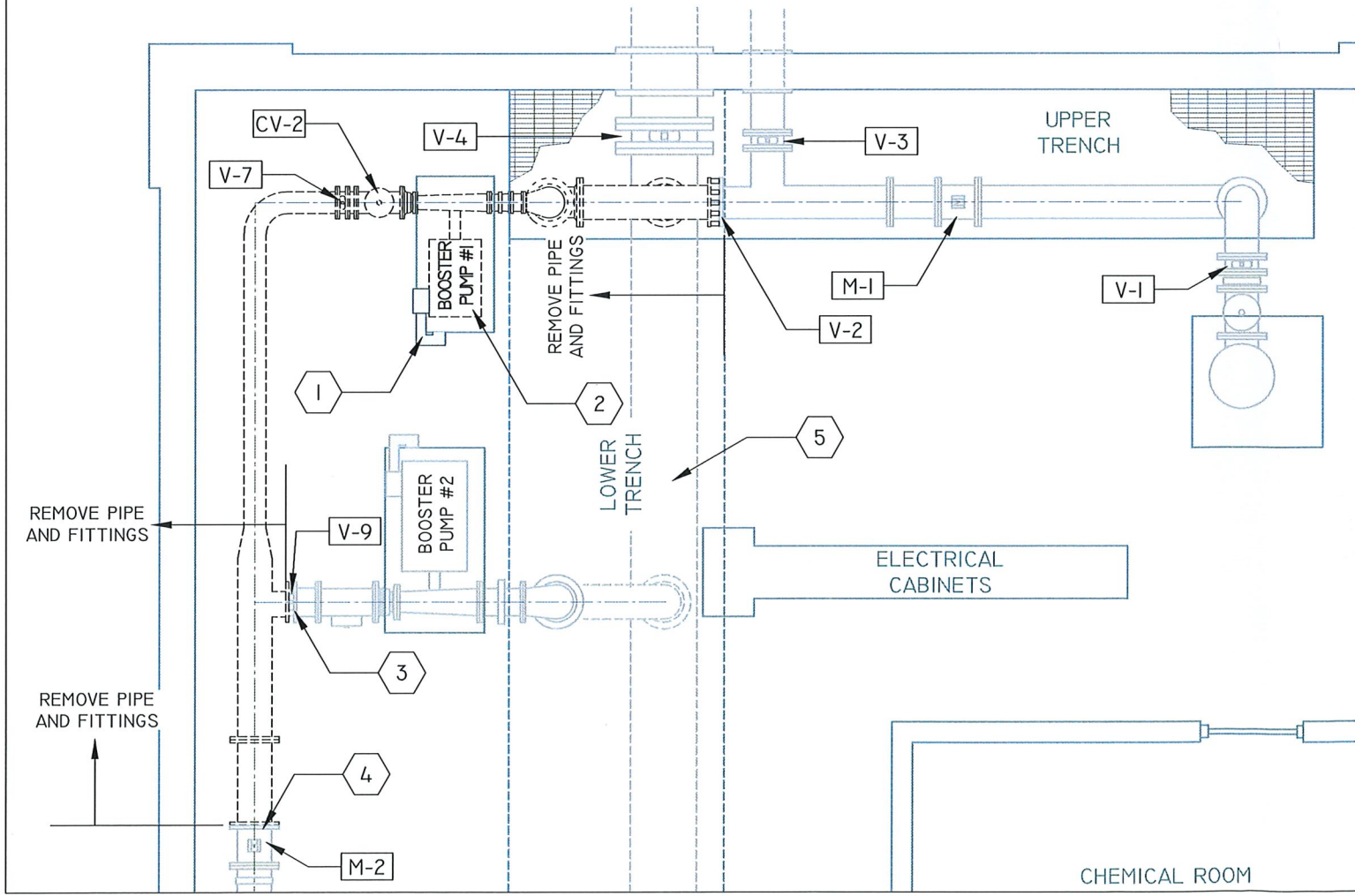

PLAN
3/16"=1'

GENERAL DEMOLITION AND CONSTRUCTION NOTES

- I. PLANNED SHUTDOWN SHALL NOT EXCEED 6 HRS. - DURING THE HOURS FROM 6:00 A.M. TO 6:00 P.M. LONGER SHUTDOWNS MAY BE POSSIBLE DURING THE HOURS FROM 6:00 P.M. TO 6:00 A.M. - COORDINATE WITH MWU.
2. CONTRACTOR TO REVIEW AND PLAN WORK TO ENSURE WORKER SAFETY WHILE KEEPING THE PUMP STATION IN OPERATION
3. PRESENT PROPOSED DEMOLITION PLAN AND CONSTRUCTION SEQUENCE FOR REVIEW BY MWU.
4. REFER TO VALVE SCHEDULE, SHEET W-1, EXISTING FLOOR PLAN, SHEET W-2, PROPOSED PIPING PLAN, SHEET W-6 AND PROPOSED PIPING SECTION, SHEET W-7.
5. WORK SHALL NOT START WITHOUT AN AGREED UPON SEQUENCE OF DEMOLITION AND CONSTRUCTION.

SUGGESTED SEQUENCE OF DEMOLITION AND CONSTRUCTION

- I. COORDINATE WITH MWU A MINIMUM OF 2 WORKING DAYS PRIOR TO SHUT DOWN THE FACILITY.
2. THE ELEVATED TANK SHALL REMAIN IN SERVICE AT ALL TIMES.
3. MWU SHALL CLOSE VALVES V-1, V-3, V-4, V-5 & V-II AND ANY APPROPRIATE YARD VALVES.
4. DEMOLISH AND REMOVE EXISTING PUMP NO. 1 SUCTION AND DISCHARGE PIPING.
5. INSTALL VALVES V-2, V-10, & V-12. ALL VALVES TO REMAIN CLOSED. NOTIFY MWU TO RE-OPEN VALVES V-4, V-5 & V-II AND ANY APPROPRIATE YARD VALVES TO RETURN TO SERVICE.
6. REMOVE BOOSTER PUMP #1 AND INSTALL NEW PUMP AND REMAINING PIPING PER PROPOSED PIPING SHEETS (W-6 & W-7).
7. PRESSURE TEST ALL NEW PIPING AND NEW PUMP.
8. DISINFECT ALL NEW PIPING AND PUMP.
9. FOLLOWING INSTALLATION OF THE PUMP, MWU WILL INSTALL WIRING AND CONTROLS
10. ASSIST MWU IN TESTING AND STARTUP OF THE PUMP. MWU WILL PROVIDE PUMP VENDOR INSPECTION OF THE INSTALLATION PRIOR TO STARTUP.
- II. PUMP OPERATION, INCLUDING, BUT NOT LIMITED TO, PUMPING CAPACITY, VIBRATION, AND VFD OPERATION WILL BE TESTED PRIOR TO ACCEPTANCE OF THE WORK.

KEYED NOTES

1. ELECTRIC POWER SUPPLY CONDUIT TO REMAIN.
2. REMOVE PUMP, MOTOR AND MOUNTING BRACKETS. MODIFY AND/OR RECONSTRUCT CONCRETE BASE AS REQUIRED FOR NEW PUMP.
3. CONNECT NEW PIPING TO 10-IN VALVE (V-9) - PROVIDE SPACERS AS NECESSARY.
4. CONNECT NEW PIPING TO 12-IN METER (M-2).
5. REINFORCED CONCRETE SLAB OVER LOWER TRENCH, EXCEPT IN GRATE AREA.

PLOT SCALE: 1" = 40'

PLOT NAME:

REV. DATE:

ORIGINATOR: CITY_OF_MADISON_WATER_UTILITY

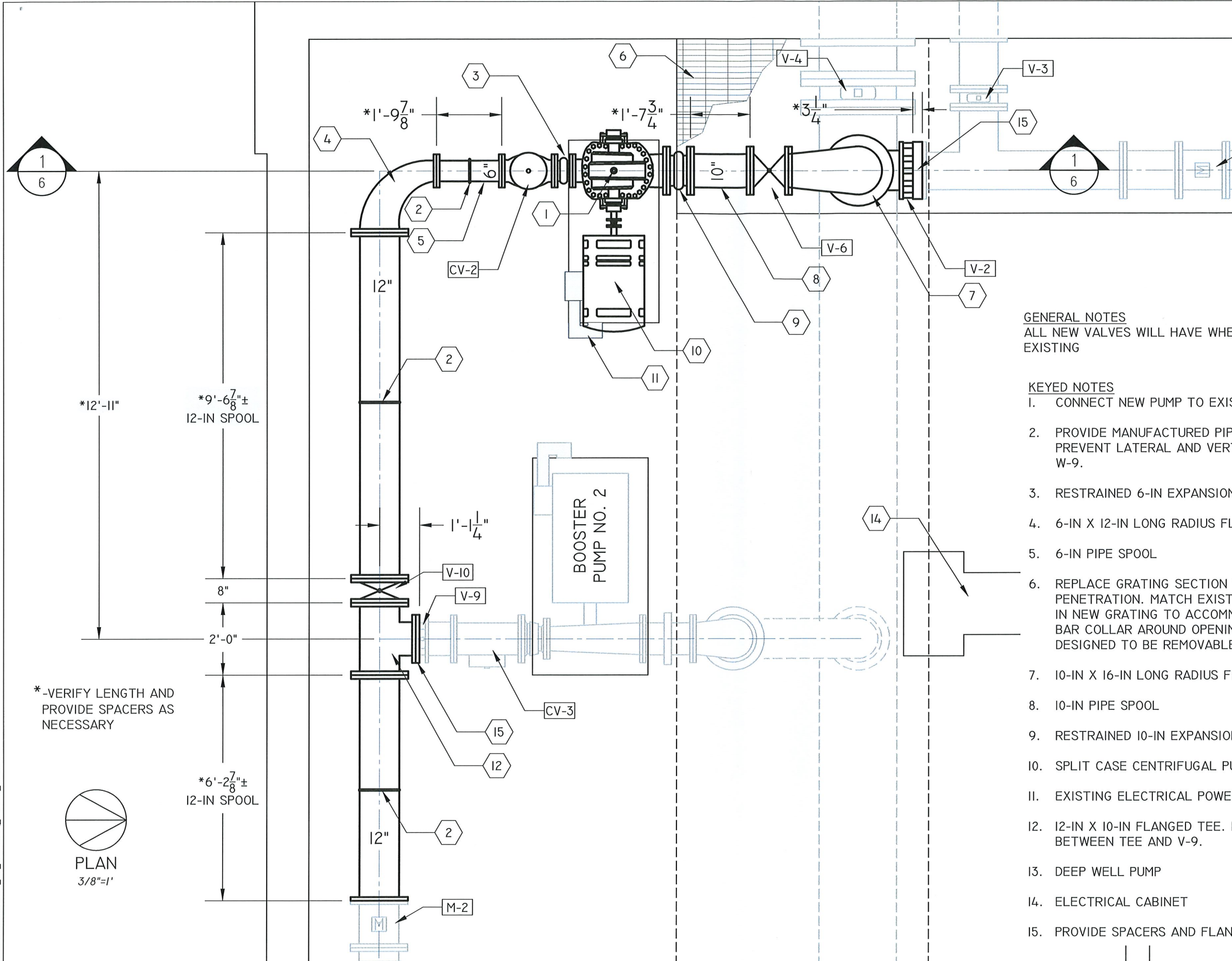

GENERAL NOTES

ALL NEW VALVES WILL HAVE WHEELED OPERATORS TO MATCH EXISTING

KEYED NOTES

1. CONNECT NEW PUMP TO EXISTING PUMP PRIMING SYSTEM.
2. PROVIDE MANUFACTURED PIPE SUPPORT SYSTEM AS REQUIRED TO PREVENT LATERAL AND VERTICAL MOVEMENT. SEE DETAIL 9-1, SHEET W-9.
3. RESTRAINED 6-IN EXPANSION JOINT
4. 6-IN X 12-IN LONG RADIUS FLANGED 90° REDUCING BEND
5. 6-IN PIPE SPOOL
6. REPLACE GRATING SECTION TO ELIMINATE OLD SUCTION PIPE PENETRATION. MATCH EXISTING GRATING AND VERIFY SIZE. CUT HOLE IN NEW GRATING TO ACCOMMODATE NEW SUCTION PIPE. WELDED STEEL BAR COLLAR AROUND OPENING REQUIRED. GRATING SECTIONS SHALL BE DESIGNED TO BE REMOVABLE. SEE DETAIL 9-2, SHEET W-9.
7. 10-IN X 16-IN LONG RADIUS FLANGED 90° REDUCING BEND
8. 10-IN PIPE SPOOL
9. RESTRAINED 10-IN EXPANSION JOINT
10. SPLIT CASE CENTRIFUGAL PUMP & MOTOR, PROVIDED BY MWU
11. EXISTING ELECTRICAL POWER SUPPLY CONDUIT TO BE REUSED.
12. 12-IN X 10-IN FLANGED TEE. PROVIDE *1-1/4" SPACER AS NECESSARY BETWEEN TEE AND V-9.
13. DEEP WELL PUMP
14. ELECTRICAL CABINET
15. PROVIDE SPACERS AND FLANGE ADAPTERS AS NECESSARY.

*-VERIFY LENGTH AND PROVIDE SPACERS AS NECESSARY



PLOT SCALE: 1" = 40'

PLOT NAME:

REV. DATE:

ORIGINATOR: CITY_OF_MADISON_WATER_UTILITY



BOOSTER PUMP #1
SIDE VIEW

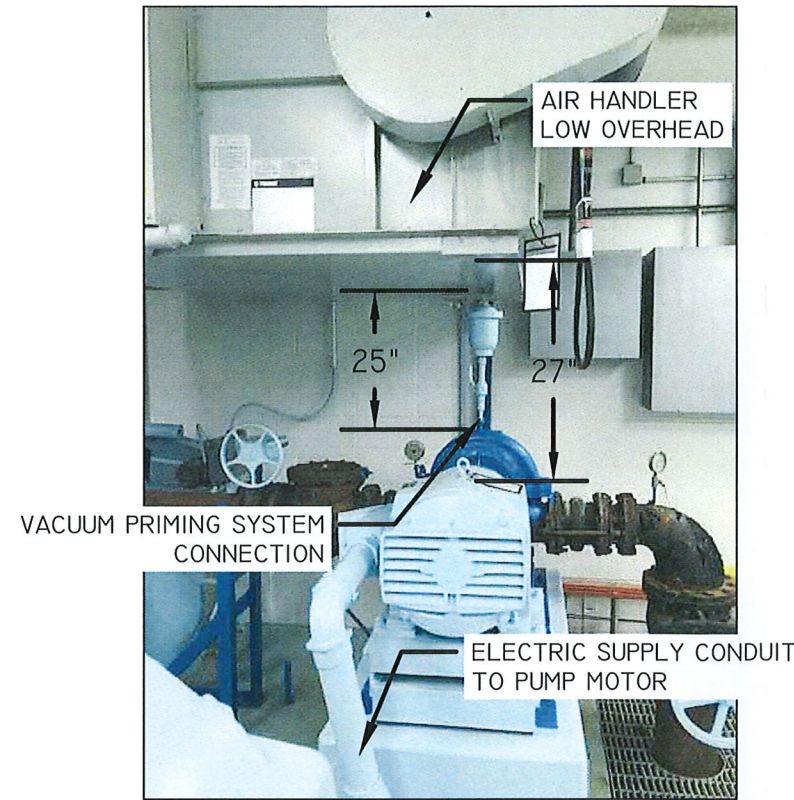

BOOSTER PUMP #1
END VIEW OF MOTOR & PUMP



BOOSTER PUMP #1
SUCTION PIPE



ELECTRIC SUPPLY CONDUIT



BOOSTER PUMP #1 DISCHARGE PIPE

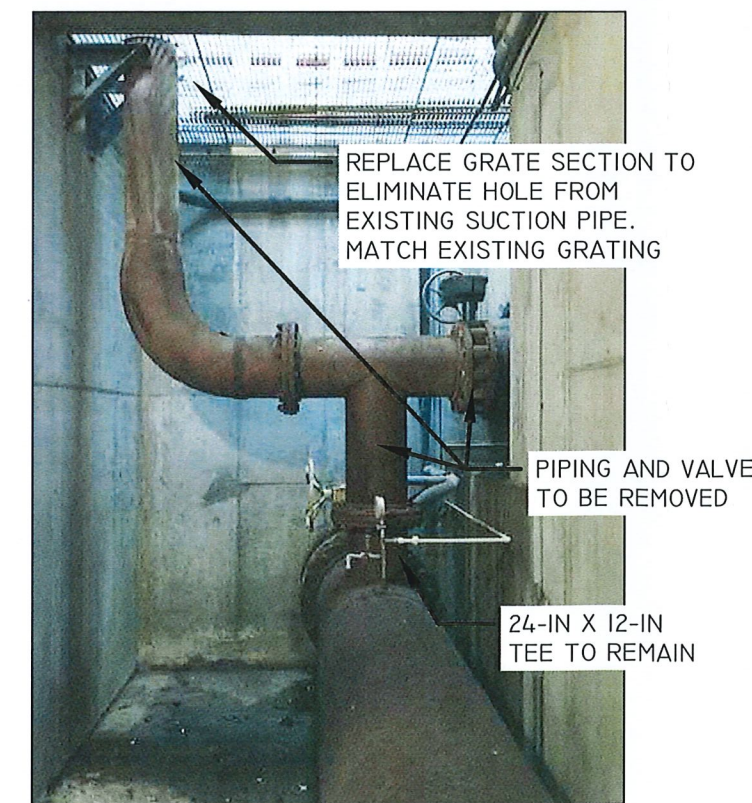

24-IN PIPE WITH VERTICAL TEE



PIPE OPENING THROUGH GRATING

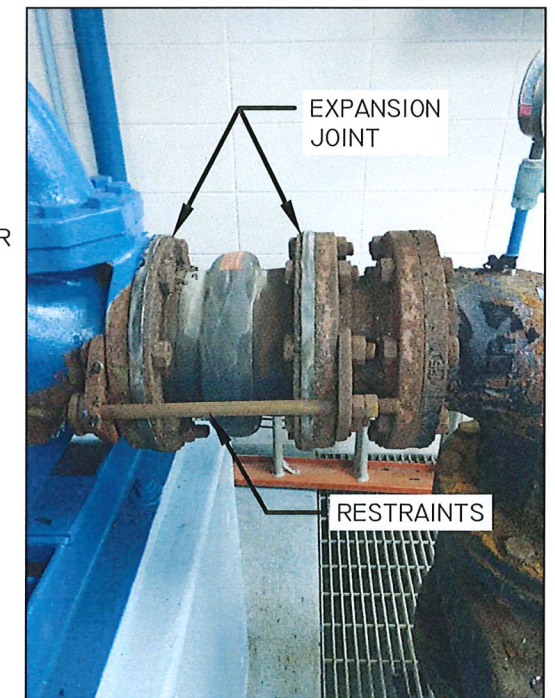

RESTRAINED EXPANSION JOINT

PLOT SCALE: 1" = 40'

PLOT NAME:

REV. DATE:

ORIGINATOR: CITY_OF_MADISON_WATER_UTILITY

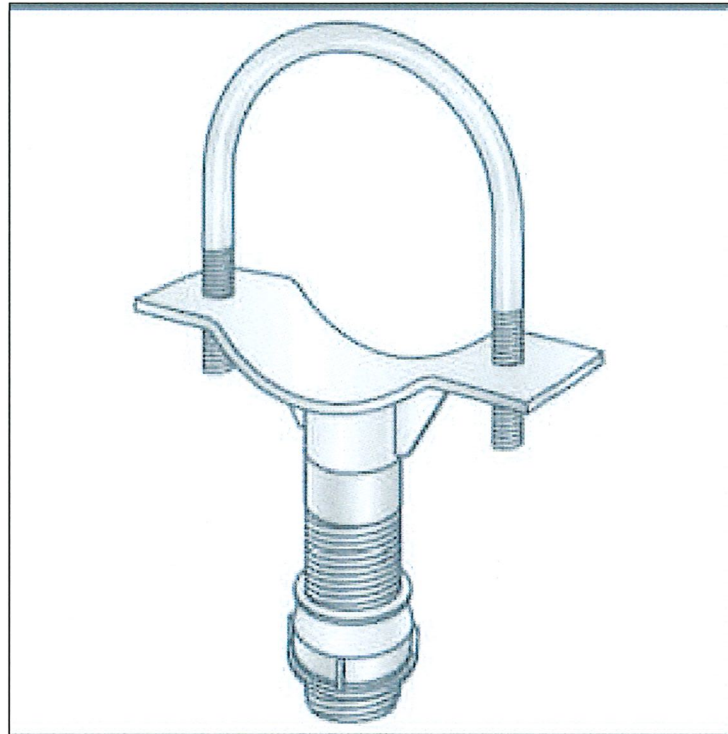

DETAIL 9-1: TYPICAL MANUFACTURED PIPE SUPPORT COMPONENT

MANUFACTURED PIPE SUPPORT SYSTEM REQUIRED TO PREVENT LATERAL AND VERTICAL PIPE MOVEMENT (AS APPROPRIATE). SUBMIT SHOP DRAWINGS OF PIPE SUPPORT SYSTEMS TO MWU FOR REVIEW AND APPROVAL PRIOR TO INSTALLATION.



DETAIL 9-2: EXISTING STEEL GRATING

1-1/2" X 3/16" STEEL BEARING BAR @ 1-1/4" SPACING WITH SWAGE LOCKED CROSS BARS @ 4" SPACING AND 1-1/2" X 3/16" STEEL BAR BANDING. PANEL SIZE 24" X 59". EQUIVALENT GRATING REQUIRED WHERE GRATING IS TO BE REPLACED. GRATING SHALL BE REMOVABLE. PIPE OPENINGS SHALL USE 1-1/2" X 3/16" STEEL BAR FOR COLLAR OR BANDING. VERIFY ALL DIMENSIONS AND SPECIFICATIONS OF EXISTING GRATING.

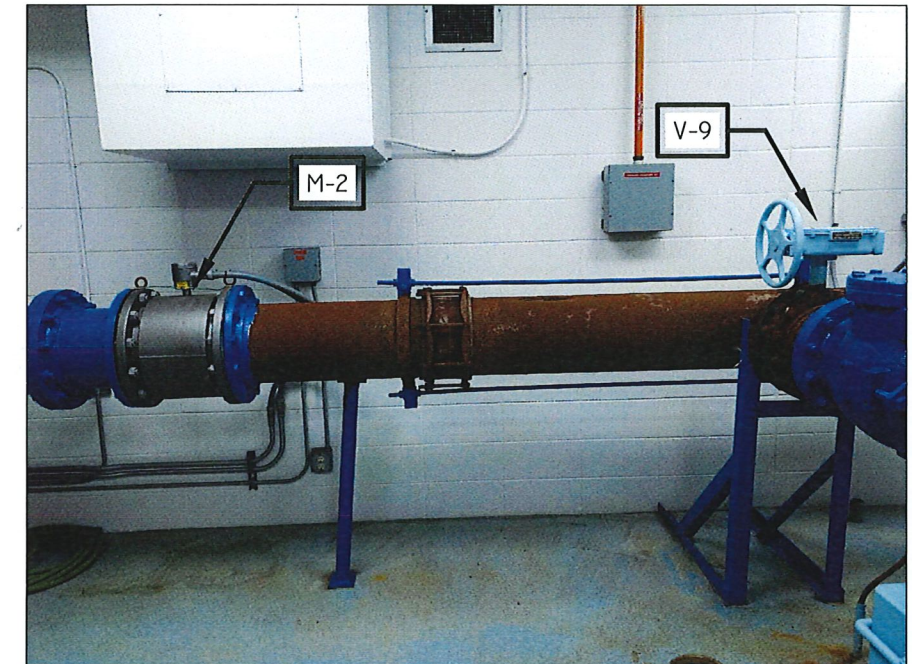

ELEVATED RESERVOIR SUPPLY PIPE DOWNSTREAM OF BOOSTER PUMP #2 DISCHARGE PIPE



ELECTRICAL CABINET TOWARD DEEP WELL (OBSCURED)



ELECTRICAL CABINET FROM ACCESS DOOR.

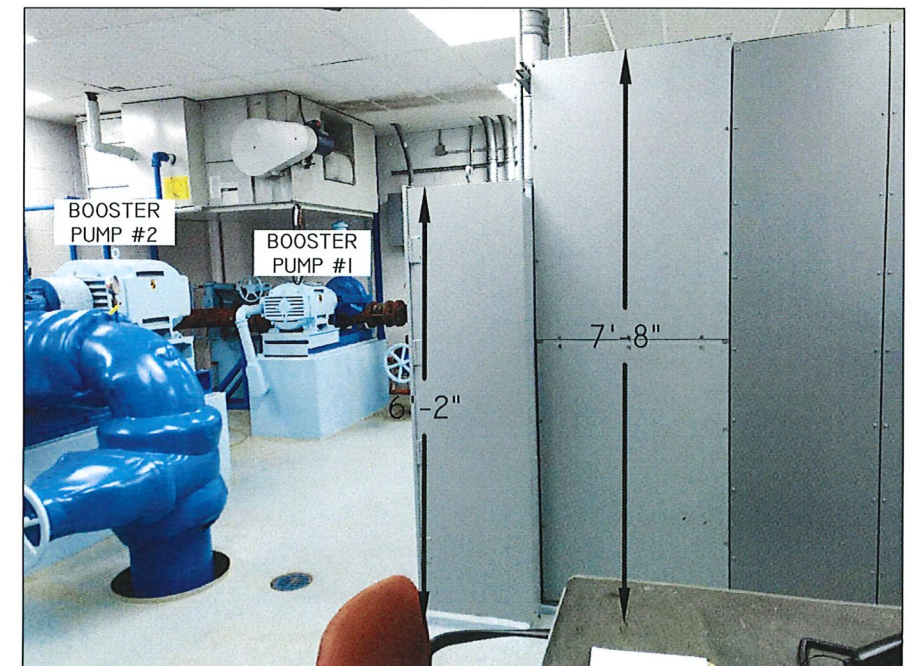

ELECTRICAL CABINET

PLOT SCALE: 1" = 40'

PLOT NAME:

REV. DATE:

ORIGINATOR: CITY_OF_MADISON_WATER_UTILITY